



Procurement Department

2 Space Drive • Taylors, SC 29687-6072 • (864) 355-1279 •

The School District of Greenville County

March 29, 2023

Invitation for Bid (IFB)

Project Reference: **Asphalt Reconditioning – Sixteen Sites**

(IFB) No: **523-22-4-28**

Bid Due: **April 28, 2023 at 11:00 A.M. EDT**

The School District of Greenville County (SDGC) invites responsible firms to submit a SEALED BID to provide Asphalt Parking Lot and Surface Repairs, Reconditioning, Striping and Painting at Sixteen Greenville County School District locations in accordance with the specifications and terms and conditions of this solicitation. All work must be completed between June 3, 2023 and August 1, 2023. For more information, the Specifications section should be consulted and is included in this solicitation.

This solicitation does not commit the District to award a contract, to pay any costs incurred in the preparation of the response to this solicitation or to procure any goods or services.

Definition of Terms

The terms, “vendor”, “contractor”, “prime contractor”, “firm”, “offeror”, “proposer”, “responder”, “supplier” or “bidder” may be used interchangeably and refers to the entity offering a proposal. These terms are defined as including a legal business association of one (1) or more persons existing at the time of the bid submission. The terms “solicitation”, “Invitation for Bid”, “Bid”, “IFB”, “Request for Proposal”, “Proposal”, “RFP”, “Quotation”, “Quote” may be used interchangeably and refers to the solicitation. The terms “Agreement”, “Award” and “Contract” means any transaction or contractual arrangement contemplated or created as a result of, arising out of, or relating to the solicitation and subsequent award. The term “Day” or “Days” refers to a calendar day, unless noted otherwise. The terms, “The School District of Greenville County”, “Greenville County Schools”, “Customer”, “Owner”, “District”, “SDGC”, “GCSD”, “GCS”, “Board of Trustees” and “Board” may be used interchangeably and refers to the entity issuing the solicitation, receiving and reviewing the bid/proposal and issuing an award. The term “Day” or “Days” refers to calendar days, unless noted otherwise.

Solicitation Schedule

Pre-Bid Conference **April 11, 2023 at 11:00 A.M. EDT**

Inquiry Deadline: **April 18, 2023 at 11:00 A.M. EDT**

Bids Due and Public Opening: **April 28, 2023 at 11:00 A.M. EDT**

Pre-Bid Conference

The District will conduct a Pre-Bid Conference on **April 11, 2023 at 11:00 A.M. EDT**. Attendance at the Pre-Bid Conference is not required but is **strongly suggested**. This conference will be held at the Procurement Department Conference Room located at 2 Space Drive, Taylors, South Carolina 29687. The promptness of each attendee at this conference is critical.

Inquiries

Questions or comments regarding this solicitation document or the process shall be forwarded, **in writing**, to Ms. Tonya A. Stroud, Senior Buyer, and Ms. Valarie Southerlin, Buyer, 2 Space Drive, Taylors, South Carolina 29687. Email addresses are: tstroud@greenville.k12.sc.us and vsouther@greenville.k12.sc.us. Inquiries and comments shall be delivered to the Procurement Department no later than **April 18, 2023 at 11:00 A.M. EDT**. Verbal questions/comments shall not be addressed at any time.

After the Inquiry Deadline, the District will issue an addendum to address any questions or changes. Any addenda will be posted on the Procurement Department website. Questions and comments received after the Inquiry Deadline will not be addressed.

NOTE: No other District personnel or representative of the District shall be contacted regarding this solicitation or the evaluation process. Vendors that attempt to contact other District personnel or representatives or obtain information in any way other than the authorized method, which is in writing to the Procurement Officer, shall have that firm's bid rejected. After the Inquiry Deadline, the District will issue an addendum to address any questions or changes. The District will not respond to late inquiries.

Project Documents

The Project Specifications and Drawings were developed and approved by staff of the SDGC Maintenance and Operations Department. The Project Specifications are included in this solicitation. The Project Drawings may be download from the SDGC Procurement Department website at:
<<https://www.greenville.k12.sc.us/Departments/main.asp?titleid=solicitations>>.

Project Schedule

The contractor will adhere to a strict project schedule, which stipulates, after issuance of a purchase order, work shall be completed between June 3, 2023 and August 1, 2023. All work must be **completed no later than August 1, 2023**. The successful contractor may work evenings and weekends with at least a 48-hour notice and approval from the Project Manager for SDGC. After hours work must be coordinated for security guard assistance. Security guard cost will be handled by SDGC.

District Schedule

Please note that the District operates on **Summer Schedule** (Monday through Thursday) beginning June 5, 2023, and ending July 27, 2023. When operating on Summer Schedule, all District locations are closed on Friday. For further information on the District calendar, interested parties may refer to the District website www.greenville.k12.sc.us.

Jobsite Visits

When visiting District sites, potential bidders should first report to the District location's front office and provide both a current driver's license and business identification. Be prepared to have your license scanned and entered into the national database of registered sex offenders. You will be asked to leave District property if your name is on this list. The District will make no further arrangements for site visits. **Note that a jobsite visit is an opportunity to review actual site conditions: a jobsite visit is not an opportunity to make verbal inquiries. Any bidder not adhering to the inquiry guidelines may cause their bid to be deemed Non-Responsive.**

District Calendar & Information

Proposers can obtain more information on the District, its calendar and standards by entering the District's website at www.greenville.k12.sc.us.

Postponements

A bid opening or a pre-bid conference shall be postponed if the District's Procurement Department is closed for any of the following reasons: 1) Causes beyond the control of the District (e.g., fire, flood, weather conditions, etc.), or 2) Emergency or unanticipated events that interrupt normal District or Procurement operations. The postponed event (opening or conference) shall automatically be rescheduled to the next full and complete District business day after the published date. A District business day does not include a day starting after an announced opening delay or a closure. Vendors should consult the District's INFOLine (864-355-3100) or local media regarding closures.

Program Specifications

All equipment and supplies shall be provided in accordance with all terms, conditions and specifications contained or referenced in this solicitation. For a complete detailed description of the program, the Bid Form, and Program Specifications should be consulted. The Program Specifications are included in this solicitation.

Throughout the duration of this contract, contract specifications, terms and conditions shall not be modified in any manner without the express written permission of a District Procurement Officer.

When applicable, brand name, model names/numbers or equivalency descriptions are intended to be descriptive, not restrictive, and are used to indicate the quality and characteristics of the product(s) along with quantities requested that will be satisfactory and acceptable to the District. Vendors shall include with the bid, supporting product data for the District's use in determining the acceptability of the proposed product(s) or manufacturer(s). When requested, vendors who do not provide adequate supportive product/manufacturer data may be considered non-responsible and will not be considered for an award.

The District reserves the exclusive right to determine if minor deviations from the listed specifications are acceptable to the District. The District retains the exclusive right to determine what constitutes a deviation. The District reserves the exclusive right to determine the relative performance and acceptability of a service and/or product(s) when compared to the solicitation specifications.

Alternate Products

The District has provided a descriptive standard for the products required. Requests for approval of alternate equipment, product, material or service shall be submitted to the undersigned Procurement Officer prior to the Inquiry Deadline. Sufficient documentation and proof or apparent equivalency shall be provided to the Procurement Officer in order for the District to make a determination of acceptability. The District is not required to ask for additional technical data; therefore, Vendors submitting such a request are advised to provide full technical information for the District's consideration.

The District reserves the exclusive right to determine the relative quality and acceptability of any proposed equipment, product, material or service when compared to the solicitation specifications. The District reserves the right to determine the acceptability of any proposed alternative service/product not requested in the invitation.

The District is not required to accept any alternate product or provide an explanation as to why an alternate product was not accepted. The District reserves the right to determine if minor deviations from the listed specifications are acceptable. The District reserves the exclusive right to determine what constitutes a deviation. A deviation is defined as a change from the stated solicitation requirements that shall have little or no material effect upon the required equipment and/or service.

Vendors shall furnish any other information the Vendor deems important for District review. The District is not required to accept any submitted, non-pertinent documentation. When applicable, the Vendor shall provide other information for any product/service that is bid. Pertinent information shall be provided with the bid so that the District may evaluate the bid properly.

Vendor’s Proposed Agreement, Contract, Lease and Terms & Conditions

The School District of Greenville County’s Procurement Code and Regulations govern and supersede any and all documents and policies, whether stated or implied. By submitting a solicitation response, the Vendor acknowledges that they have had the opportunity to inquire about the District’s Procurement Code, this solicitation and other pertinent policy.

Should the Vendor require the District to sign any contract, any document and/or any agreement, the Vendor shall inquire in writing if the District would consider its proposed contract, document and/or agreement and shall provide such contract, document and/or agreement or other pertinent documents to the District’s undersigned Procurement Officer prior to the Inquiry Deadline which is noted in the solicitation. Submittal of any document(s) does not mean acceptance of the document(s) and the information contained therein, by the District or that a Vendor is considered by the District to be responsible, the bid responsive or the services/equipment/materials acceptable.

The District shall not accept any proposed agreement, contract, lease, terms and conditions or any other contractual document which may be included with the bid or submitted separately, that has not been previously submitted prior to the Inquiry Deadline or is referenced to be enforceable in the future. The District shall not accept any terms and conditions which would be prejudicial to other Vendors and/or would materially change the solicitation. Software licensing agreements are included in this requirement.

The District shall not accept, enter into or sign any proposed agreement(s), document(s), offer(s), contract(s), leases(s) and/or provision(s) that materially conflicts with the District’s General Terms and Conditions, the requirements of this solicitation or which are determined not to be in the best interest of the District.

This solicitation and the District’s General Terms and Conditions shall govern and take precedence as the contract between the District and the awarded proposer. The terms of the agreement between the District and the successful Vendor shall comply with the requirements contained in this solicitation and the District’s General Terms and Conditions which are incorporated herein.

Proposals or bids that include agreements, terms, conditions, contracts and/or contract provisions which conflict with the District’s General Terms and Conditions (attached) and/or which were not submitted prior to the Inquiry Deadline and/or were not approved by the District and/or conflict with the requirements of this solicitation, may be rejected by the District as non-responsive. The rights and authority to make such a determination is reserved solely to the Procurement Officers of the District’s Procurement Department.

Interested Vendors that submit a bid or proposal that contradicts this solicitation and which is not in compliance with the requirements of this solicitation, including the District’s General Terms and Conditions, acknowledge and understand that, by doing so, its proposal may be deemed non-responsive by the District. Potential Vendors that cannot agree to the above conditions should not expect to have a proposal considered for an award.

Instruction for submittal of Bids Responses

All bids must be in a sealed envelope and have clearly marked on the envelope:

Sealed Bid Enclosed

Project Reference: Asphalt Reconditioning – Sixteen Sites

IFB No. 523-22-4-28

Mail or hand-deliver the bid to:

**The School District of Greenville County
2 Space Drive
Taylors, South Carolina 29687
Attn: Procurement Department**

By submitting a solicitation response, the Vendor acknowledges that it has had the opportunity to inquire about the District's Procurement Code and Regulations, this solicitation and other pertinent District policy. If not submitting a bid, please submit a "NO BID" letter indicating the reason for not doing so. The submitted sealed bid must be signed by an authorized individual who may bind the Vendor to provide the service(s) and/or product(s) in accordance with the specifications contained in this IFB.

The official time due time for a solicitation response is maintained according to the Time/Date Stamp located in the District's Procurement Department. All solicitation responses shall be received in the District's Procurement Department, 2 Space Drive, Taylors, South Carolina 29687, no later than the time specified in this solicitation. Solicitation responses shall be in the physical possession of a Procurement Department employee prior to the due time or the solicitation response shall be determined to be late once the due time has occurred.

Faxed or emailed bids shall not be accepted.

NOTE: Vendors who hand deliver the bid are responsible for physically handing the bid to a Procurement Department employee prior to the bid due time/date. Do not hold the bid until the recording meeting begins. Do not deliver the bid to any other location or individual.

Responses that are in another District location, room, department or other area at the solicitation due time other than the Procurement Department shall not be accepted. If there is doubt as to the location of the Procurement Department, Vendors may contact the District for directions. The District is not responsible for the Vendor's or its representative's interpretation of any directions provided. The District is not responsible for traffic, parking availability, road closures, delivery services or weather conditions.

Vendors may mail their bid, however the District assumes no responsibility for the delivery of any solicitation, addendum, solicitation response or any other correspondence by the U.S. Postal Service, a delivery service, electronic transmission, facsimile or any other method.

NOTE: PROPOSALS / BIDS RECEIVED OR DATE STAMPED AFTER THE BID DUE/PUBLIC OPENING TIME SHALL NOT BE ACCEPTED OR CONSIDERED.

Bid Form

Enclosed is the Bid Form to be used when submitting a bid. Only this Bid Form may be used. Do not change the Bid Form or insert a different unit of measure or unit of pricing.

Prices stated on the Bid Form shall remain in effect for the duration of the stated work end date of this solicitation (**August 1, 2023**). Pricing submitted shall be inclusive of all costs that the bidder expects the District to pay.

Bidders must complete the Bid Form or insert the letters "N/A" if the bidder chooses not to submit a price. Failure to complete the form may cause the bidder to be determined non-responsive.

The bid price(s) shall include all materials, labor, rental equipment, rental tools, and consumables necessary to provide and deliver the product(s).

NOTE: Bidders that alter the Bid Form are qualifying the bid response and are subject to disqualification.

Vendor's Information

A cover letter on the Vendor's corporate stationery should include any information the Vendor determines to be important regarding the evaluation of the bid.

Insurance (When Applicable)

IMPORTANT: Please include a copy of the bidder's certificate of liability insurance and Workman's Compensation *in the sealed bid package* with the bid.

Liquidated Damages (When Applicable)

Two-Hundred Fifty Dollars (\$250) per Day.

Bid Security (When Applicable)

None required.

Performance and Payment Bonds (When Applicable)

None required.

Subcontracting

No portion of this contract shall be subleased, assigned, transferred, or conveyed without the expressed prior written approval from a SDGC Procurement Officer. Proposed subcontractors shall be identified in the bid.

Bid Response Certification

Interested Vendors are hereby notified that a "Bid Response Certification" statement is included within the solicitation Bid Form and that by signing the certification statement, with no alterations allowed, the Vendor agrees to be bound by the terms and conditions of the solicitation and by the District's General Terms and Conditions included herein by reference. The Bid Response Certification statement that is included with this solicitation shall be signed and returned with the bid. Should a Vendor decide not to sign the Certification Statement, the reasons for the decision shall be noted on a separate page to be included within the sealed bid package.

An interested Vendor that submits a bid that contradicts this solicitation and which is not in compliance with the requirements of this solicitation, including the District's General Terms and Conditions, acknowledge and understand that, by doing so, its bid may be deemed nonresponsive by the District.

A Vendor who takes exceptions to any portion of this solicitation may be deemed "nonresponsive" and may not be eligible for an award. The rights and authority of such determination are reserved solely by the Procurement Officers of the District's Procurement Department.

Certification of Drug-Free Work Place

Enclosed is the Certification of Drug-Free Work Place to be used when submitting a bid package. Only this form shall be used and it shall be completely filled out and returned within the sealed bid package.

Evaluation of Bids

Attendance at the public recording is not required in order to have a bid evaluated.

All bids will be reviewed for the purpose of determining responsiveness. Any bid that does not meet the salient requirements of the IFB will be deemed non-responsive. To determine responsibility, all information provided by the Vendor concerning its availability to perform fully the contract requirements, including the integrity and reliability of the Vendor, will be reviewed. This project is on a critical timeline, and a vendor's ability to provide the product within the specified period of time will be examined and included in the evaluation. The

submission of a bid for review does not necessarily qualify the Vendor as being responsible or the bid as being responsive. Failure to provide specific information as requested for use in an evaluation will cause the bid to be disregarded.

The bid responses will be evaluated based on the factors as detailed in this solicitation. The Vendor(s) deemed by the District as responsible and who offer(s) the most advantageous rate(s) may be awarded the contract if all other terms and conditions are acceptable to the District and if in the District's best interest.

Vendors must clearly mark the words "**Confidential**" or "**Protected**" next to each section of the bid that the Vendor considers to be proprietary or may contain confidential information. In no manner or situation will pricing be considered confidential. The District shall have the sole, exclusive right to determine whether such confidential notations are valid and subject to public release.

The District may request written or oral clarifications of any offer received. However, the District may, at its sole discretion, refuse to accept in full or partially, the response or clarification given by any Vendor.

Vendors are cautioned that the evaluators are not required to request a clarification of the bid; therefore, **all offers should be complete and reflect the most favorable terms to the District.** The District reserves the right to reject any and all offers when such rejection is deemed to be in the best interest of the District.

It is understood and agreed that the bid is for the services and products specified or a District-approved equal. The District does not guarantee that the District will require any specified project or item.

The District reserves the right to accept or reject, in part or in entirety, any or all bids or portions of bids submitted by any Vendor and to waive any informalities or technicalities so as to purchase in the best interest of the District. The District reserves the right to interpret the acceptability of the proposed services and supplies when meeting the intent for use as determined by the end user.

The District reserves the right to negotiate with all responsible Vendors and to cancel in part or in entirety, this solicitation if it is in the best interest of the District. This solicitation does not commit the District to negotiate, hold discussions, award a contract, pay any costs incurred in the preparation of the response to this solicitation or to procure any services and/or supplies.

Award

This is a Sealed Bid solicitation. The project will be awarded as **one (1) total lot** to the lowest pricing, responsible bidder whose responsive bid is in the best interest of the District and at the discretion of the District's evaluators. The District may conduct discussions with responsible Vendors that submit bids for the purpose of clarification to assure a full understanding of the requirements of the IFB and the clarification of any bid. Any award shall encompass all of the requirements of the solicitation. The initial period of performance begins after issuance of a Purchase Order.

After the contract is awarded, no additional costs will be considered. Hidden or undisclosed costs will not be accepted.

The District cannot guarantee that any particular vendor will be selected or any business conducted as a result of this solicitation. The failure of a specific vendor to receive business, once an award has been made, shall not be grounds for contract controversy.

The award statement will be posted in the Procurement Department, 2 Space Drive, Taylors, South Carolina. The award will also be posted on the Procurement Department website. The public may review this statement during regular office hours. Interested parties may call the Procurement Department at (864) 355-1279 to determine if an award has been posted. It is the responsibility of the Bidder to physically confirm such posting.

IMPORTANT: Student and Staff Safety

The successful Vendor shall be required to verify that criminal conviction inquiries/checks and pertinent criminal background inquiries/checks have been conducted on all of its employees and the subcontractors who may interact with staff and/or students during the performance of the awarded Scope of Work or who may have a need to enter District property related to the performance of the contract or who may have access to personal student or District personnel information.

All inquiries and background checks must be conducted on a monthly basis or more frequently or as required by the District.

Persons who are identified as a Sex Offender or violator as defined by the South Carolina Code of Laws (Ann. 2006), Article 7, Sections 23-3-400 to 23-3-500 or other statute or any other states' statutes and persons who

have been convicted of Violent Crimes as defined by the South Carolina Code of Laws, 1976, Section 16-1-60; are prohibited from entering any of The School District of Greenville County schools at any time, including all District grounds and all District facilities. Persons employed by or under the direction of the Vendor or any subcontractor who are under investigation or have been charged with crimes and/or convicted of crimes against children or crimes of a sexual or violent nature shall not be allowed on District property.

While performing under this solicitation and subsequent award, a firm/individual/supplier who delivers material and/or a service to a District site at the direction of a Vendor and/or a subcontractor shall be considered under the supervision of the Vendor and/or subcontractor and shall be in compliance with this requirement. Contractor's and subcontractor's employees are not to interact with students at any time. Vendor's and subcontractor's employees are not to be in areas where students are present or may be present without prior authorization from the school's principal or designee.

The District may in its sole discretion terminate any existing contract for the failure by the awarded Vendor, its subcontractors or any representative of the Vendor or subcontractor to observe this requirement or for any violation of this solicitation's requirements. No penalty or other costs shall be levied against the District as a result of its decision to terminate the contract or award.

In addition to the above obligations of the successful Vendor, all persons and contractor personnel having contact with students and/or any individual who enters onto District property may be subject to a national criminal background check at the discretion of the District prior to entry upon District property and the performance of any duties. All individuals entering District property shall be screened nationally for criminal sex offenses/Sex Offender status on automated equipment at each school or site.

Alcoholic Beverages, Illicit Drugs, Smoking, and Weapons

The successful Vendor shall not permit its personnel, representative or any subcontractor or other personnel to possess upon District property or within any vehicle transporting students and staff, any alcoholic beverages, illicit/non-prescribed drugs, tobacco products or weapons. Alcoholic beverages, illicit/non-prescribed drugs, tobacco products and weapons are not allowed on District property at any time. Any vendor related actions involving or the possession of, any of the aforementioned items while on District property may cause a cancellation of any award/agreement, at no cost to the District. Criminal charges may apply. Personnel who appear to be under the influence of any substance shall not be allowed to transport or come into contact with students or enter or remain on District property.

Jurisdiction

The District is not an agency of the state and is not governed by the South Carolina Consolidated Procurement Code and Regulations. The District is governed by its own Procurement Code and Regulations.

Contract Termination for Cause

The District reserves the right to terminate this solicitation or resulting agreement upon a thirty (30) day notice, when in the best interest of the District. Termination of any contract by the District for cause, non-performance, default or negligence on the part of the successful Vendor shall be a retained right. Termination costs levied against the District shall not apply and the thirty (30) calendar day termination notice requirement shall be waived. The default provisions shall apply when a contract is terminated for cause.

The District reserves the right to terminate an award/contract when the health and safety of students and staff are threatened or for the awarded firm's non-compliance with state law or the terms and conditions of the solicitation.

The District reserves the right to terminate the continuation of any project, agreement, service or award resulting from this solicitation when funding has not been appropriated. The District does not anticipate canceling a project or an agreement; however, it shall reserve the right to act in the best interests of the District and its constituents.

Default

In case of default by the Vendor, the District reserves the right to purchase any or all services / items in default in the open market, charging the Vendor with any additional costs. The Vendor that is determined to be in default shall not be considered a responsible Vendor until the assessed charge as been satisfied.

Vendor's Relationship with the District

The successful Vendor shall be independent of the District. None of the Vendor's employees shall be deemed for any purpose to be employees, agents, or servants of the District, but shall at all times serve as employees, agents, or servants of the Vendor for whom and at whose direction they shall act. No acts performed for or representations made, whether written or oral, by the Vendor to third parties shall bind the District. The Vendor shall be solely responsible for the withholding and payment of all federal, state, and local personal income, social security, unemployment, workers compensation, and other payroll taxes for its employees. The District shall have no liability of any sort for the Vendor's employees.

The successful Vendor shall be responsible for any loss or damage to property (in the sole opinion of the District) owned by the District and in the Vendor's possession or control. No portion of this contract shall be subleased, assigned, transferred or conveyed without written approval from a Procurement Officer of the District prior to or after issuance of the Intent to Award. The District will NOT provide office space, utilities and operating expenses. This includes phone, copier, fax and postage expenses.

Vendor Responsibility

Responsibility of the Vendor shall be ascertained for a contract awarded by the District based upon full disclosure to the District concerning capacity to meet the terms of the contract and based upon a past record of performance for similar contracts. The failure of a proposer to supply information promptly to the District may be grounds for a determination of non-responsibility with respect to such proposer. Failure to provide requested information may result in rejection of a solicitation response and/or suspension and/or debarment of the proposer.

The District shall be entitled to audit the books and records of a Vendor or any subcontractor under any negotiated contract or subcontract other than a firm fixed price contract to the extent that such books and records relate to the performance of such contract or subcontract. Such books and records shall be maintained by the Vendor for a period of three (3) years from the date of final payment under the prime contract and by the subcontractor for a period of three (3) years from the date of final payment under the subcontract, unless a shorter period is authorized in writing by a District Procurement official.

Due care and diligence have been used in the preparation of the scope of work and/or the specifications and the information contained therein is believed to be substantially correct. However, the responsibility for determining the full extent of the exposure and the verification of all information presented herein shall rest solely upon the Vendor. The District will not be responsible for any errors or omissions in the Vendor's response nor for the failure on the part of the Vendor to determine the full extent of the solicitation requirements and exposures.

The Vendor may ask questions subject to the Inquiry Deadline and the previously stated inquiry instructions.

The successful Vendor shall perform this project in compliance with all Federal and State requirements concerning fair employment of all employees and applicants. Bidding Vendors shall promote the employment of the disabled and disadvantaged and shall employ without regard or discrimination due to the reason of ethnic background, age, color, religion, gender, national origin or physical disability. Vendors should provide information regarding the use of minority subcontractors if applicable or if requested by the District. Assistance to small, minority and disadvantaged firms and individuals is available in accordance with the District's Minority Business Enterprise Utilization Plan, which is available by contacting the Procurement Officer.

Use of District Name

The awarded Vendor shall not use the name of the District in advertising or in seeking or joining into contracts with suppliers, customers or for any other manner. The Vendor shall make all of its contracts in its own name and the awarded Vendor shall be responsible for its financial obligations and contracts, not the District.

Cooperative Purchasing (When applicable)

The District's Procurement Code and Regulations authorizes the use of cooperative purchasing practices with regard to other public procurement units. Accordingly, any South Carolina school district, state, city or county agency or other public procurement unit may participate in any resulting award if agreeable to the District, the successful Vendor and the other public procurement unit.

No other public procurement unit is required to make use of this capability as participation is at the discretion of the other public procurement unit. This District is not bound by any other public entities' solicitation, award or other contract.

The District shall not guarantee the participation of another public procurement unit nor be responsible for any resulting business or non-business with any other entity. Purchase Orders, delivery arrangements, payments and any other type of contractual documentation or performance shall be the responsibility of the actual participating public procurement unit, not The School District of Greenville County. The successful Vendor shall hold harmless the District, its employees, Administration, Board of Trustees and its representatives for any loss or damage as the result of the action or inaction of another public procurement unit.

Prepayment

The District shall not approve or process any payment to the Vendor, its subcontractors or suppliers prior to project completion. Vendor requirements or requests for "up front", partial payment or pre-payment shall not be authorized. Vendor that require such conditions in their bid and/or file invoices or payment requests after an award, but prior to performance completion, shall have their contract cancelled with no penalty levied against the District.

Procurement Card and ACH Processing (If applicable)

The District has the capability to pay the majority of vendor invoices with a District managed Procurement Card (P-Card) and/or an Automated Clearing House (ACH) processing method. The District reserves the right to request that the awarded vendor process invoice/payment transactions by use of the District P-Card or ACH processing method. Failure by the vendor to provide P-Card and/or ACH transaction processing capabilities shall not be grounds for rejection of a proposal nor shall it create a contract controversy. **Any discounts offered**

by the vendor as the result of the District's use of the P-Card or ACH processing should be noted in the solicitation response on a separate page entitled Procurement Card and ACH Processing Capability.

Educational Technology Services Requirement

The following requirement has been prepared by the District's Education Technology Services (ETS) department and is enforceable when applicable:

"For all COTS (commercial off-the-shelf applications), the Vendor shall submit security audit documentation which meets State and Federal law along with applicable regulatory standards including, but not limited to: the South Carolina Public Records Act, Family Educational Rights and Privacy Act (FERPA), Health Insurance Portability and Accountability Act (HIPAA), Pupil Privacy Rights Act (PPRA), Individuals with Disabilities Education Act (IDEA), Gramm-Leach Bliley Act (GLBA), and Payment Card Industry Data Security Standard (PCI-DSS). Applications must also meet or exceed verifiable Greenville County School District security review and security application testing specifications, including, but not limited to: Open Web Application Security Project (OWASP), The Web Application Security Consortium (WASC), and United States Computer Emergency Readiness Team (US-CERT) National Vulnerability Database (NVD) as part of the Request for Proposal or Invitation for Bid submission."

Iran Divestment Act – Certification (Dec 2015)

(a) The Iran Divestment Act List is a list published by the Authority pursuant to Section 11-57-310 that identifies persons engaged in investment activities in Iran. Currently, the list is available at the following URL: <http://procurement.sc.gov/PS/PS-iran-divestment.phtm> (.). Section 11-57-310 requires the government to provide a person ninety days written notice before he is included on the list. The following representation, which is required by Section 11-57-330(A), is a material inducement for the State to award a contract to you. (b) By signing your Offer, you certify that, as of the date you sign, you are not on the then-current version of the Iran Divestment Act List. (c) You must notify the Procurement Officer immediately if, at any time before posting of a final statement of award, you are added to the Iran Divestment Act List. [07-7A072-1].

Iran Divestment Act – Ongoing Obligations (Jan 2015)

(a) You must notify the procurement officer immediately if, at any time during the contract term, you are added to the Iran Divestment Act List. (b) Consistent with Section 11-57-330(B), you shall not contract with any person to perform a part of the Work, if, at the time you enter into the subcontract, that person is on the then-current version of the Iran Divestment Act List. [07-7A072-1]

Bidder's Rights

Bidders may have the right to protest this solicitation or its subsequent award in accordance with Article XIV of the District's Procurement Code. Should a protest period end on a day that the District is closed; the protestor may file by 5:00 P.M. the following full day that the District is open for business.

South Carolina Illegal Immigration Reform Act

By signing its bid or proposal, Contractor certifies that it will comply with the applicable requirements of Title 8, Chapter 14 of the *South Carolina Code of Laws* and agrees to provide to the District, upon request, any documentation required to establish either: (a) that Title 8, Chapter 14 is inapplicable both to Contractor and its subcontractors or sub-subcontractors; or (b) that Contractor and its subcontractors or sub-subcontractors are in compliance with Title 8, Chapter 14. Pursuant to Section 8-14-60, "A person who knowingly makes or files any false, fictitious, or fraudulent document, statement, or report pursuant to this chapter is guilty of a felony and upon conviction, must be fined within the discretion of the court or imprisoned for not more than five years or both." Contractor agrees to include in any contracts with its subcontractors language requiring its subcontractors to (a) comply with the applicable requirements of Title 8, Chapter 14, and (b) include in their contracts with the sub-subcontractors language requiring the sub-subcontractors to comply with the applicable requirements of Title 8, Chapter 14. (An overview is available at www.procurement.sc.gov).

State and Federal Laws and Regulations *(Revised 10/13/22)*

The School District of Greenville County requires adherence and itself adheres to all applicable State and Federal laws and regulations including “2 CFR, Subtitle A, Chapter II Subpart D, 200.322 Domestic Preferences for Procurements”.

The successful vendor’s work, end product, and/or services shall meet all local, state and federal requirements.

Permits, Licenses and Taxes

The Vendor shall, at its own expense, prior to an award and prior to commencing services/operations on behalf of the District or under contract with the District, acquire all necessary permits, licenses and other approvals as required by law to provide the required services and/or actions in conjunction with a contract award with the District. It is recommended that Vendors contact the following to learn of any pertinent requirements or licenses:

1. The South Carolina Secretary of State’s office (www.scsos.com)
2. The South Carolina Department of Revenue
3. The City of Greenville Business License department (as applicable)
4. The County of Greenville

The District shall not interpret the requirements of other public entities on behalf of the Vendor.

Vendors shall remain in compliance with all applicable statutes and pertinent regulations throughout the term of performance. Should any permits or licenses be revoked or lapse during the period of performance, the undersigned Procurement Officer shall be notified immediately.

The Vendor shall pay all excise taxes, retail taxes and other fees imposed. The Vendor assumes full responsibility for payment of all State and Federal taxes for unemployment, pensions or any Social Security legislation for all its employees and will further comply with all requirements that may be specified in regulations hereafter promulgated by the District’s administrative officials.

Contractor Licensing

Prior to the bid due date and time and throughout the program/project, the bidding firm, the Prime Contractor and any Subcontractors, shall be licensed in full accordance with the provisions of Section 40-11-10 through 40-11-340 of the Code of Laws of South Carolina, 1976, as amended.

The firm and/or presenting agent must be duly licensed to do business in the State of South Carolina and Greenville County. The District recommends that Vendors contact the South Carolina Secretary of State office and the Greenville City business license office for more information. The District shall not interpret these requirements on behalf of the Vendor. The successful Vendor shall meet all Federal, state, and local statutes and other requirements prior to award of the project.

Indemnity

NOTE: The Vendor agrees to indemnify and hold harmless the District and the District’s members, officers, employees, representatives, servants and agents, from and against any and all liabilities, losses, damages, costs and expenses of any kind (including, without limitation, reasonable legal fees and expenses in connection with any investigative, administrative or judicial proceeding, whether or not designated a party thereto) which may be suffered by, incurred by or threatened against the District or any members, officers, employees, servants or agents of the District on account of or resulting from injury, or claim of injury, to person or property arising from the awarded proposer’s actions or omissions relating to this Agreement, or arising out of the proposer’s breach or failure to perform any term, covenant, condition or agreement herein provided to be performed by the proposer.

The District shall not indemnify and/or hold harmless any proposing entity or its representatives as this action is not statutorily allowed by South Carolina law.

Certification Regarding Debarment and other responsibility matters (Dec. 2021)

- (a) (1) By submitting an Offer, Vendor certifies, to the best of its knowledge and belief, that-
- (i) Vendor and/or any of its Principals-
 - (A) Are not presently debarred, suspended, proposed for debarment, or declared ineligible for the award of contracts by any state or federal agency;
 - (B) Have not, within a three-year period preceding this offer, been convicted of or had a civil judgment rendered against them for: commission of fraud or a criminal offense in connection with obtaining, attempting to obtain, or performing a public (Federal, state, or local) contract or subcontract; violation of Federal or state antitrust statutes relating to the submission of offers; or commission of embezzlement, theft, forgery, bribery, falsification or destruction of records, making false statements, tax evasion, or receiving stolen property; and
 - (C) Are not presently indicted or civilly for, or otherwise criminally charged by a governmental entity with, commission of any of the offenses enumerated in paragraph (a)(1)(i)(B) of this provision.
 - (ii) Vendor has not, within a three-year period preceding this offer, had one or more contracts terminated for default by any public (Federal, state, or local) entity.
- (2) "Principals," for the purposes of this certification, means officers; directors; owners; partners; and, persons having primary management or supervisory responsibilities within a business entity (e.g., general manager; plant manager; head of a subsidiary, division, or business segment, and similar positions).
- (b) Vendor shall provide immediate written notice to the Procurement Officer if, at any time prior to contract award, Vendors learns that its certification was erroneous when submitted or has become erroneous by reason of changed circumstances.
- (c) If vendor is unable to certify the representations stated in paragraphs (a)(1), Vendor must submit a written explanation regarding its inability to make the certification. The certification will be considered in connection with a review of the Vendor's responsibility. Failure of the Vendor to furnish additional information as requested by the Procurement Officer may render the Vendor non-responsible.
- (d) Nothing contained in the foregoing shall be construed to require establishment of a system of records in order to render, in good faith, the certification required by paragraph (a) of this provision. The knowledge and information of an Vendor is not required to exceed that which is normally possessed by a prudent person in the ordinary course of business dealings.
- (e) The certification in paragraph (a) of this provision is a material representation of fact upon which reliance was placed when making award. If it is later determined that the Vendor knowingly or in bad faith rendered an erroneous certification, in addition to other remedies available to the State, the Procurement Officer may terminate the contract resulting from this solicitation for default.

[02-2A035-1]

If not submitting a bid, please submit a “NO BID” letter indicating the reason for not doing so.

The District appreciates each firm’s interest in this project.

Tonya A. Stroud

Tonya A. Stroud
Senior Buyer

Enclosures: Certification of Drug-Free Work Place
Bid Response Certification
Program Specifications / Scope Work
Bid Form
General Terms and Conditions

Program Specifications – Asphalt Reconditioning – Sixteen Sites

IFB# 523-22-4-28

Multiple Site Asphalt Parking Lot Reconditioning

1. **PURPOSE:**

The intent and purpose of this Invitation for Bids is to establish a contract to provide asphalt parking lot and surface repairs, reconditioning, striping and painting at Greenville County Schools. Requirements will be different at each location.

2. **SCOPE OF SERVICE**

A. **WORK INCLUDED:** The contractor shall provide all labor, materials, tools, equipment, supervision, and service required for the complete and satisfactory performance of requested work and services as specified. This work shall include, but not be limited to, asphalt surface preparation/cleaning, removal of any and all debris, routing of cracks, full depth asphalt repair, crack sealing, sealcoating, and repainting of all parking lot markings on Greenville County Schools owned property. Work to be performed as a complete turn-key and unit price basis as indicated.

B. **QUALITY OF WORKMANSHIP:** All work shall be quality work performed according to the standards of the industry, and to the complete satisfaction of Greenville County Schools. All work performed shall comply with all State and Federal regulations with regards to human safety. Contractor shall strictly adhere to all applicable statutes, laws, regulations, ordinances and guidelines, including, without limitation, those promulgated by ADA, EPA, OSHA, CPSC, SCDHEC, SCDOT, State of South Carolina, Greenville County, and City of Greenville authorities. If requested work could violate any of these, submit to the district representative. A written ruling/response will be obtained that the contractor shall follow.

C. **PERSONNEL QUALIFICATIONS:** Personnel used for the performance of this work shall be properly trained and qualified for work of this type. The contractor is required to train their staff in all asphalt parking lot/surface construction procedures, prior to starting any work on the school jobsite. Greenville County Schools reserves the right to refuse to accept services from any personnel deemed by GCS to be unqualified, disorderly, or otherwise unable to perform assigned work. Contractor is solely responsible for performance and discipline of its employees.

D. **COMMUNICATION:** Provide management level contact for district representatives to discuss concerns regarding services or performances.

- 1) Each crew or team shall have a foreman or lead. This person must be able to communicate with the school office staff, the school athletic director, and the district's representative, verbally and in writing, in English.
- 2) Contractor is solely responsible for performance and discipline of its employees.
- 3) The Contractor shall inform the school's front office staff of its presence and purpose for any and all visits. Before beginning work at any District site, the Contractor is required to enter the school building by way of the Main/Front Office and shall record the names of the service operators/technicians on the visitor sign-in log. Sign-in and Sign-out shall be done at each school upon entering and leaving District property.
- 4) When requested, the contractor shall cooperate with any ongoing investigation involving economic loss or damage to any district or school personnel property.
- 5) Notify the district representative of any unsafe condition seen and noted, that is outside of the scope of this specification.
- 6) No later than five (5) working days prior to work being performed on site, the Contractor will contact the District Representative and provide notice of services. This notification will include the scheduled services, number of employees, starting time, and estimated time on site.
- 7) The contractor will schedule all work so that noise and equipment operations do not affect teaching of classes, use of outside play or athletic areas, and parking lots.
- 8) All requested site meetings during the contract period, will be at no cost to GCS.

E. **SAFETY:** It is the Contractor's responsibility to ensure that all employees and suppliers are trained in proper safety procedures for the type of work to be performed.

- 1) Contractor will direct his employees, and suppliers to notify the owner immediately if they observe any unsafe work practices or conditions.
- 2) Contractor shall provide his employees with state-of-the-art safety equipment necessary to the work in a safe manner.

- 3) Ensure that any records, personal equipment, or tools used in the performance of the work are not accessible to any person not associated with this contract.
- 4) Contractor shall strictly adhere to all applicable statutes, laws, regulations, ordinances and guidelines, including, without limitation, those promulgated by ADA, EPA, OSHA, SCDHEC, SCDOT, State of South Carolina, Greenville County, and City of Greenville authorities. The Contractor will be responsible for providing all notification signage with required information.
- 5) The Contractor shall take all precautions for safety of, and shall provide all protection to prevent damage, injury or loss to:
 - a. Persons and Students
 - b. Employees
 - c. Other property at the site or adjacent thereto, such as windows, structures, paved areas, fencing, utilities and vehicles.
- 6) The Contractor shall give notices and comply with applicable laws, ordinances, rules, regulations and lawful orders of public authorities bearing on safety of persons or property for their protection from damage, injury or loss.
- 7) Contractor is responsible for providing proper signage, barricades, and other necessary devices to keep the site safe and protect the work being performed.
- 8) The Contractor shall promptly remedy damage and loss to property caused in whole or in part by the Contractor. This includes performing work with equipment when the ground is wet and causing ruts/unevenness to areas surrounding the schools or playgrounds.
- 9) The District is not responsible if the Contractor leaves his vehicle or equipment on District property. The District is not responsible for any damages to the Contractor's vehicle or equipment.
- 10) Leave all work areas in a clean and safe condition. Remove debris from District site on a daily basis and dispose at any approved disposal site. Contractor is to provide its own dumpsters or vehicles for debris storage or removal. Contractor is not to use any school dumpster.
- 11) Prior to the commencement of any work or during the work, GCS retains the right to inspect materials, plans, and work methods to ensure proper application.
- 12) Contractor shall submit to the District Representative for each school location, **SDS** forms for all material used.

F. **PROJECT COMPLETION / WARRANTY:** At the completion of a project, the contractor shall contact the District Representative by phone or by email to inform him of project completion. A follow up meeting may take place on site. Contractor shall warranty products and workmanship for a period of two years minimum. Manufacturer shall guarantee the material for two years from date of finished application against chalking, checking, cracking, fading, discoloration, or other adverse effects from ultra-violet rays, from weather moisture, or from weather temperatures.

G. **INSURANCE:** Insurance required shall be written for not less than any limits of liability specified in the Contract documents (listed below) or required by laws of South Carolina, whichever is greater.

- 1) Workman's Compensation Insurance – Statutory, required of all contractors regardless of number of employees.
B
- 2) Comprehensive General Liability shall include: Contractor's liability, Owner's and Contractor's liability, and Contractual Liability, all having limits of not less than:

- Bodily Injury \$ 500,000 --- per occurrence
\$1,000,000 --- aggregate
- Property Damage \$ 500,000 --- per occurrence
\$ 500,000 --- aggregate

- 3) Comprehensive Automobile Liability shall include coverage for all owned, non-owned, and hired automotive equipment, all having limits of not less than:

- Bodily Injury \$ 500,000 --- per person
\$1,000,000 --- per occurrence
- Property Damage \$ 200,000 --- per occurrence

- 4) Comprehensive Excess ("umbrella") coverage shall be provided in an amount of not less than \$1,000,000.

Important Note: Please include a copy of the bidder's certificate of liability insurance and Workman's Compensation in the sealed bid package.

H. **INVOICING:** The Contractor shall provide the District with invoices within thirty (30) calendar days of work completion. Contractor shall note the District project location and service provided on each invoice. Contractor shall send all invoices in duplicate to the following address:

The School District of Greenville County
Coordinator of Athletic Fields & Grounds
Attn: Tom Vaughan
2 Space Drive
Taylors, South Carolina 29687

Or email invoice to the district representative swindham@greenville.k12.sc.us

Invoices must be issued by the awarded bidder(s). The district representative will not be responsible for payment of invoices not billed after sixty (60) days of agreed invoice date. Any costs associated with a service older than sixty (60) days are not the responsibility of the location or the District.

Important Note: Invoices shall detail each charge by line item clearly displaying the basis for all charges.

The District does not pay from invoices with incomplete information or from statements.

The District shall not honor any charges for **minimum billings, mobilization charges, or travel/mileage charges**. Any bid or solicitation response which requires a minimum billing per trip, or a minimum billing per school, or a minimum billing per repair will not be considered.

Payment

The District's customary terms for payment of a problem-free invoice are net thirty (30) calendar days.

3. SCHOOL LOCATIONS TO BE SERVICED

A site visit is recommended for verifying current conditions and scope of work needed to be performed. Also, several of these sites will have Summer School programs and other District Maintenance projects that will need this work both coordinated logistically and scheduled appropriately.

- **Alexander Elementary** – 1601 Bramlett Road, Greenville, SC 29611
- **Armstrong Elementary** - 8601 White Horse Rd. Greenville 29617
- **Berea High** - 201 Burdine Drive, Greenville 29617
- **Blythe Academy** - 100 Blythe Drive, Greenville 29605
- **Cherrydale Elementary** – 302 Perry Rd. Greenville, SC 29609
- **Greenview Child Development Center** – 625 Old Piedmont Highway, Greenville, SC 29605
- **Monarch Elementary** - 224 Five Forks Road, Simpsonville 29681
- **Monaview Elementary** - 10 Monaview St., Greenville 29617
- **Paris Elementary** - 32 East Belvue Road, Taylors 29687
- **Paul L. Dunbar Child Development Center** – 200 Morgan Street, Greer, SC 29651
- **Ralph Chandler Middle** - 4231 Fork Shoals Road, Simpsonville 29680
- **Sevier Middle** - 1000 Piedmont Park Road, Greenville 29609
- **Slater Marietta Elementary** – 100 Baker Circle, Marietta, SC 29661
- **Southside High** - 6630 Frontage at White Horse Rd, Greenville 29605-3300
- **Sterling Middle / Charles Townes Center** - 99 John McCarroll Way, Greenville 29607
- **Thomas E. Kerns Elementary** - 6650 Frontage at White Horse Rd, Greenville 29605-3300

4. GENERAL ASPHALT RECONDITIONING SPECIFICATIONS

A. Summary

- 1) Listed Greenville County Schools will have all asphalt areas cleaned, cracks ¼” and greater routed and filled, potholes/failed asphalt areas removed and full depth repaired, seal coated, and have all parking lot markings repainted and striped.
- 2) **Work is to be done between June 3rd and August 1st.**

- 3) Asphalt areas are to be reconditioned in this order of work:
 - a. Full depth repairs
 - b. Surface cleaning
 - c. Crack sealing
 - d. Sealcoating
 - e. Painting
- 4) No coal tar products are to be used
- 5) Contractor will work with school principal and district representative to ensure that there is no disruption of school functions, instruction, and drop-off or pick-up of children and staff.
- 6) All products are to be used in accordance with manufacturer's specifications.
- 7) Material used meets or exceeds all applicable ASTM standards for material quality.
- 8) Contractor is responsible for protecting their work and is solely responsible for repair of any damaged work. Contractor is responsible for all quality-control issues and for accidental or incidental damage caused during the work.
- 9) Contractor will ensure that newly applied pavement markings are protected from traffic until it has cured and the method of protecting does not pose a hazard to any person that accesses the site. Any damage to any markings shall be repaired by the contractor at their expense.
- 10) Contractor is responsible for providing temporary toilet facilities.
- 11) All work will be performed by skilled professionals and will be executed in a workmanlike manner in accordance with the best standards and practices of the trade.
- 12) Finished repaired/replaced asphalt surfaces shall be even/flush with all joints, surrounding surfaces and structures.
- 13) If any current sidewalk, manhole, curb, sewer clean-out, utility, irrigation, gate, fencing, or handrail, is to be removed or is damaged, then these are to be repaired or replaced to match current conditions at the expense of the contractor.
- 14) Concrete curb/parking stops may be removed and reinstalled by the contractor. These are not to be damaged, splattered or covered with any material, nor painted. Contractor will be responsible for replacement.
- 15) Any damages to existing structures or pavement during this project, is the sole responsibility of the contractor to fix or replace, before project is considered complete. Payment will be for completed project.

B. Submittals

- 1) Submit manufacturer's product data for each intended product to be used in accordance with enclosed bid. This is to include all preparation, application, and installation instructions along with the type of material the product consists of.
- 2) Manufacturer's certification that materials to be used meet the specified requirements and are suitable for intended application.
- 3) Project references where the submitted products have been used during a five-year period.
- 4) Manufacturer's warranty documentation for each product.
- 5) Verification that each product meets or exceeds ASTM standards.
- 6) Provide a timeline of events beginning from the receipt of a purchase order through final **project completion on August 1st**.
- 7) See Contractor Qualifications
- 8) Others as contained in bid specifications.

C. Contractor Qualifications

- 1) The contractor shall have and submit a listing of related asphalt construction, repair, sealcoating, and striping work covering a minimum of five (5) years.
- 2) Contractor shall be approved by the manufacturer of the materials to be used.
- 3) Submit any playground industry professional memberships or certifications currently held.
- 4) List any subcontractors and their qualifications that are to be used. Subcontractors are under the liability and responsibilities contained within this bid, under the awarded contractor.

D. Delivery, Handling, and Storage of Materials to be Used

- 1) Contractor is responsible for all logistics to receive and store materials at every location that work is to be performed.
- 2) Contractor is responsible for any damaged materials and is required to remedy all issues to ensure that material to be used is in accordance with manufacturer's recommendations if compromised in any way.
- 3) Store and handle materials in accordance with manufacturer's instructions.
- 4) Keep materials in manufacturer's original, unopened containers and packaging until application.
- 5) If any materials to be used are considered HAZARDOUS, the contractor is responsible for proper handling and disposal according to applicable regulations. The contractor is to notify the district representative if any material deemed as such is identified.

- 6) Contractor is responsible for any trash receptacles/dumpsters needed for disposal of any refuse or job created waste, along with removal from site after work has been performed, at own expense. School dumpsters are not to be used.

E. Weather Conditions

- 1) Do not apply materials when surface and ambient temperatures are outside the temperature ranges specified by the product manufacture.
- 2) Surface and air temperature should be a minimum of 50° F (10° C) and rising.
- 3) For Sealcoating, do not apply on rainy, foggy, or extremely humid days, or when rain is in the forecast within 24 hours.
- 4) Contractor is responsible for any damage that may occur due to weather conditions, and is responsible to remedy and repair any issues or problems to make the repair work whole, according to manufactures recommendations and industry standards.

SECTION A – SURFACE PREPARATION SPECIFICATIONS

- 1) All asphalt surfaces are to be thoroughly cleaned.
- 2) All asphalt surfaces must be free from all dirt, dust, debris, and chemical residues.
- 3) Grass is to be excavated and removed along the edges of pavement to find the true edge of pavement.
- 4) Asphalt surfaces that are embedded with hardened accumulations of grease, gum, hard clay, dust, silt, and any other foreign matter that cannot be removed by mechanical means, must be pressure washed.
- 5) Wipe, scrape, or burn excessive buildup of oil, grease, and gasoline spots.
- 6) Deeply impregnated oil or other petroleum products, may need a manufacture recommended primer or sealer applied before other asphalt work, as specified in this bid, is to take place.
- 7) All surfaces must be dry before any work is to be done.
- 8) All dirt, debris, and contaminates are to removed from the site by the contractor.
- 9) Any excavated area with slopes or grades requiring erosion control will be seeded with Bermuda grass and have properly staked biodegradable erosion control blanket put in place.
- 10) All storm drain inlets are to be protected so as not to allow any debris, waste water, material/product spillage, or contaminated run-off, to enter any storm drainage systems.

SECTION B – FULL DEPTH ASPHALT REPAIR SPECIFICATIONS

- 1) Areas to receive full depth repairs are shown on included drawings with this bid.
- 2) Standard duty asphalt is for walking paths, athletic courts, play pads, and parking lots. A drawing for standard duty asphalt specifications is included with this bid.
- 3) Heavy duty asphalt is for bus loops, dock receiving areas, drives/car loops, and trash dumpster areas. A drawing for heavy duty asphalt specifications is included with this bid.
- 4) Cut edges of damaged areas by mechanical means. Saw cutting is permitted. No skip/wheel cutting or jackhammering will be allowed.
- 5) Corners of repair areas shall be at right angles.
- 6) Excavate material in a manner that will protect the asphalt that will remain. Asphalt that is damaged will be repaired by the contractor at their sole expense.
- 7) Remove existing pavement that has failed.
- 8) Repair in accordance with the Standard or Heavy duty specified drawings that are included. This will be determined by location and function. See 1) and 2) of this section.
- 9) If asphalt damage is determined to be caused by tree roots or other organic matter, remove all roots 2' feet beyond the damaged area and construct back according to included drawings and specifications.
- 10) Wet, damaged, or unsatisfactory sub-grade material shall be removed and replaced with suitable material, not less than 6". Proper base material is to be added and compacted to 96%.
- 11) If suitable subgrade is found, repair according to methods listed below.
- 12) Prime/apply to all areas of repair, including bottom and all sides with asphalt binder/tack coat.
- 13) Fill and compact in suggested lifts, hot mix asphalt. Compact with vibratory-plate compactor or mechanical asphalt roller.
- 14) Final repair shall be flush and level with adjoining surfaces.
- 15) If any seems are visible between repair and adjoining surfaces, see crack sealing specifications.

- 16) Contractor will use steel plates at the end of the day for any areas left that are excavated to a depth of 2" inches or greater. Steel plates will withstand traffic loading without movement, meet ASTM A 36, anchored securely to prevent movement, and to resist bending, vibrations, etc. under traffic.
- 1) METHOD 1 - "3+3" FDR of small areas (potholes)
 - a. Cut out area around damaged pavement as a clean rectangle.
 - b. Excavate subgrade underneath to a depth 6" below pavement surface. Dispose of all debris off-site.
 - c. Compact remaining subgrade with motorized tamp.
 - d. Add 3-inch layer of crusher-run gravel, and compact with tamp again.
 - e. Apply tack coat to pavement edges, and allow to dry.
 - f. Pave area at 3-inch depth using type C surface asphalt.
 - g. Roll new asphalt flush with existing pavement.
 - h. Sweep work area clean.
 - 2) METHOD 2 - "4+4" FDR of areas requiring heavy duty asphalt or failed base layer
 - a. Cut out area around damaged pavement as a clean rectangle.
 - b. Excavate subgrade underneath to a depth 8" below pavement surface. Dispose of all debris off-site.
 - c. Compact remaining subgrade with motorized tamp.
 - d. Add 4-inch layer of crusher-run gravel, and compact with tamp again.
 - e. Apply tack coat to pavement edges, and allow to dry.
 - f. Pave area at 4-inch depth using type C surface asphalt.
 - g. Roll new asphalt flush with existing pavement.
 - h. Sweep work area clean.
 - 3) METHOD 3 - "Blade and roll" FDR of large areas (greater than 10' x10')
 - a. Cut out pavement around each damaged area as marked.
 - b. Remove any soft material from subgrade.
 - c. Dispose of all debris off-site.
 - d. Add new crusher-run gravel as needed, then aerate existing subgrade using tined bucket on skid-steer tractor.
 - e. Compact gravel subgrade with motorized tamp.
 - f. Apply tack coat to pavement edges, and allow to dry.
 - g. Determine if area requires standard duty or heavy-duty asphalt
 - h. Pave areas at full original depth using type C surface asphalt (large patches in driveway will be paved at a depth of 4 inches).
 - i. Roll new asphalt flush with existing pavement.
 - j. Sweep work area clean.

SECTION C – CRACKSEALING SPECIFICATIONS

- 1) Prepare surface according to SECTION A – SURFACE PREPARATION SPECIFICATIONS
- 2) Cracks MUST BE thoroughly prepped using one of 2 methods:
- 3) Routing the crack using a mechanical router, mechanical grazing wheel or compressed hot air lance. Either method must thoroughly clean the crack and create a reservoir to hold crack sealant material, routed to create reservoir. Simply blowing the cracks with compressed air is not acceptable preparation.
- 4) Crack should be routed to 1" inch depth.
- 5) Maximum crack width is 2" inches.
- 6) Cold pour filler is NOT ALLOWED.
- 7) Use only Hot-pour sealant and it must be premium parking lot grade, not road-grade.
- 8) Use only wand-injected oil-jacketed machinery. Crack sealant will be melted in a conventional oil-jacketed unit equipped with an agitator and applied using a pump and wand system.
- 9) Gravity flow roll-around pour pots are NOT ALLOWED.
- 10) Confine hot poured sealant material within the crack. Clean any overflow of sealant from the pavement surface. If the method of filling cracks results in an excessive amount of material on the pavement surface, stop and correct the operation to eliminate the excess material.
- 11) Cracks banded FLUSH (no more than 1/16th"). No wider than 2.5"-disc footprint. Do NOT use squeegee.

- 12) Only apply to cracks that are 1/4" wide or more.
- 13) Only seal cracks that are not in failed, depressed, or alligatored areas that requires full depth repairs.

SECTION D – SEALCOATING SPECIFICATIONS

- 1) DO NOT use Coal Tar products.
- 2) Before sealcoating, all full depth repairs, crack sealing, and any other work should be complete.
- 3) Prepare surface according to SECTION A – SURFACE PREPARATION SPECIFICATIONS
- 4) Design Mix should be strictly adhered to the Product Data Sheet.
- 5) Provide the appropriate coverage rate of BULK product gallons, according to the Product Data Sheet.
- 6) Submit your design mix process to ensure proper mixing.
- 7) Contractor may have to submit certification that the appropriate quantity of material to meet this specification has been purchased and is on-site. Quantities of sealer, modifier, and sand may be requested to verify prior to application.
- 8) Use 3% sand mix.
- 9) To assure material consistency, all materials will be blended in a bulk, agitated, minimum 500-gallon tank.
- 10) Before application, a product data sheet may be required to verify that the mix does not contain asbestos or coal tar products.
- 11) Apply 2 coats of sealcoat at a rate of 0.12 – 0.15 gallons per square yard, per coat, of undiluted material
- 12) Spray 2 coats at 100% coverage rate PER COAT. (EACH COAT should receive 100% of the recommended coverage rate of bulk gallons. NOT 100% after 2 coats, but 100% coverage rate on coat 1, and 100% coverage rate on coat 2.) For example, if the area to spray is 10,000 SY, and the coverage rate is 0.1 SY/G, the bulk gallons sprayed should be 1000g PER COAT, for a total of 2000g bulk material.
- 13) Between coats: The first coat must not only dry, but also cure sufficiently to prevent pickup before the second coat is applied. Shady or sheltered areas may require a longer drying time. To determine whether the first coat is cured sufficiently, use the thumb test. At various locations and while exerting approximately 10 pounds of pressure, twist thumbprint 90 degrees. Lack of pickup on thumb indicates sufficient curing of the first coat, and indicates you should be able to continue with your second coat.
- 14) Submit how you monitor your coverage rates to guarantee proper coverage rates for each section sprayed.
- 15) Be prepared to show records of coverage rates for each section sprayed.
- 16) Sealcoat will be applied by either pressurized spray application equipment or self-propelled squeegee equipment.
- 17) Pressurized spray equipment shall be capable of spraying pavement sealer with sand added.
- 18) Self-propelled squeegee equipment shall have at least 2 squeegee or brush devices (one behind the other) to assure adequate distribution and penetration of sealer into bituminous pavement.
- 19) Application equipment must be capable of keeping material thoroughly mixed and homogenous throughout the application process.
- 20) Equipment used must be capable of supplying a sufficient quantity of material for uniform application over the entire width of the application mechanism to provide a uniformly coated surface.
- 21) Cure time will vary according to temperature and humidity at the time of application. Insufficiently cured films wear prematurely. Lower temperatures, high humidity and lack of direct sunlight will prolong the cure time. Higher temperatures, lower humidity and direct sunlight accelerate the cure process.
- 22) Before the second coat is to be applied, allow the first coat to dry sufficiently to withstand light vehicular and pedestrian traffic without damaging or scuffing the coating.
- 23) After the application of the last coat, allow the coating to cure at least 20-24 hours under good drying conditions prior to opening to traffic or painting.

SECTION E – PARKING LOT PAINTING SPECIFICATIONS

- 1) Contractor will record all pavement markings by photograph or drawing to maintain painting layout following full depth repairs, crack sealing, or sealcoating. All existing markings will be required to be **repainted and in their existing colors**. This is also for curbs, and special markings such as assigned numbers on curb stops at high schools, etc.
- 2) Comply with applicable requirements of SCDOT for pavement marking.
- 3) Prepare surface according to SECTION A – SURFACE PREPARATION SPECIFICATIONS
- 4) Allow at least 24 hours after final sealcoat application before painting.
- 5) All paint to be thermoplastic
- 6) Corrections to existing markings may be required.
- 7) Additional markings will be required:

- a. Addition of stop bars at the end of parking areas and where stop signs are present
 - b. Where school signage indicates; “VISITOR” and “RESERVED” to be painted in parking areas
- 8) All ADA handicap parking stalls and markings shall be light blue thermoplastic.
 - 9) All other parking stall lines shall be painted white thermoplastic.
 - 10) Lines shall be 4” inches in width.
 - 11) Stop bars and STOP legends shall be installed at the ends of parking aisles and everywhere there is a stop sign present.
 - 12) Stop bars and STOP legends shall be white thermoplastic. STOP lettering shall be a minimum of 36” in height.
 - 13) “VISITOR” and “RESERVED” to be painted in white thermoplastic.
 - 14) Enhanced Crosswalks (ECW) will be required for all new crosswalks. ECWs shall be 1 foot thick by 6 feet wide (min.). Spacing between strips is 2 feet. All crosswalks shall be made of thermoplastic materials.
 - 15) Stop bars shall be used and be placed no closer than 4 feet from any part of the marked crosswalk.
 - 16) Directional arrows and other miscellaneous pavement markings such as cross-hatching, median markings, etc. shall be white thermoplastic.
 - 17) Yellow markings shall be used only for centerline markings to separate traffic traveling in the opposite direction, medians, or for yellow curbing to prohibit parking where applied.
 - 18) Fire Lanes shall be in red thermoplastic with white lettering or as currently painted.
 - 19) Apply with pressurized line striping spray equipment at a wet thickness of 15 to 20 wet mils.
 - 20) Apply graphic symbols and lettering with paint-resistant, die-cut stencils, that are firmly secured to the pavement. Paint to prevent any overspray or clouding outside of stencil. Apply paint so that it cannot run beneath stencil.
 - 21) Only sharp, crisp, clean lines without any overspray, clouding, or runs, will be accepted.

SECTION C – SITE MAPS, LOCATION OF FULL DEPTH REPAIRS, AND REQUIRED DRAWINGS

See site maps, individual parking lot layouts, and specification drawings for:

- location of schools and aerial view of each school
- location of full depth asphalt repairs
- drawings for repair specifications

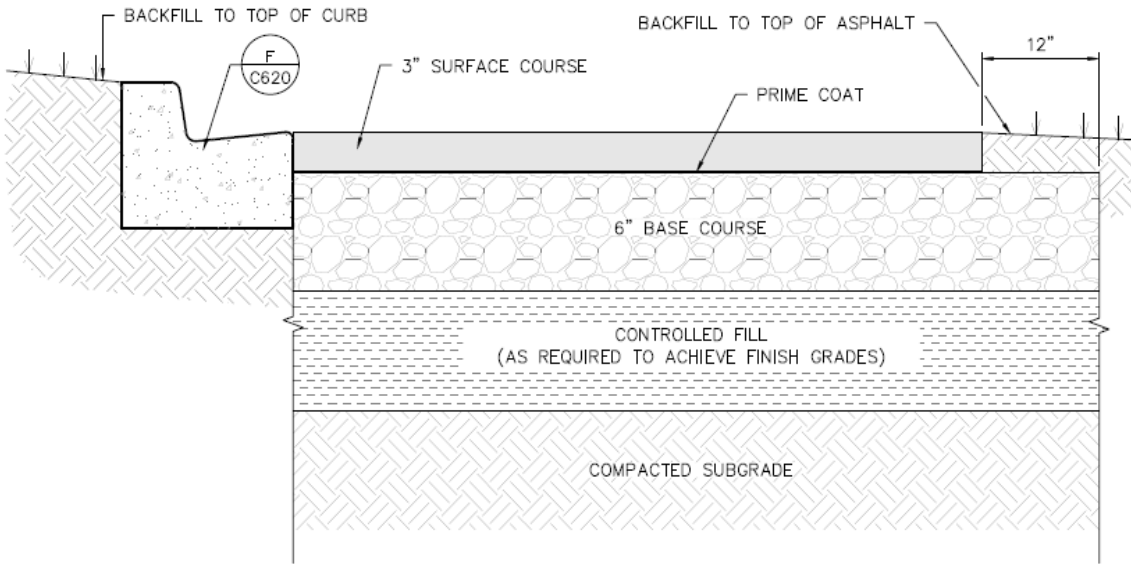

A STANDARD DUTY ASPHALTIC CONCRETE PAVEMENT SECTION

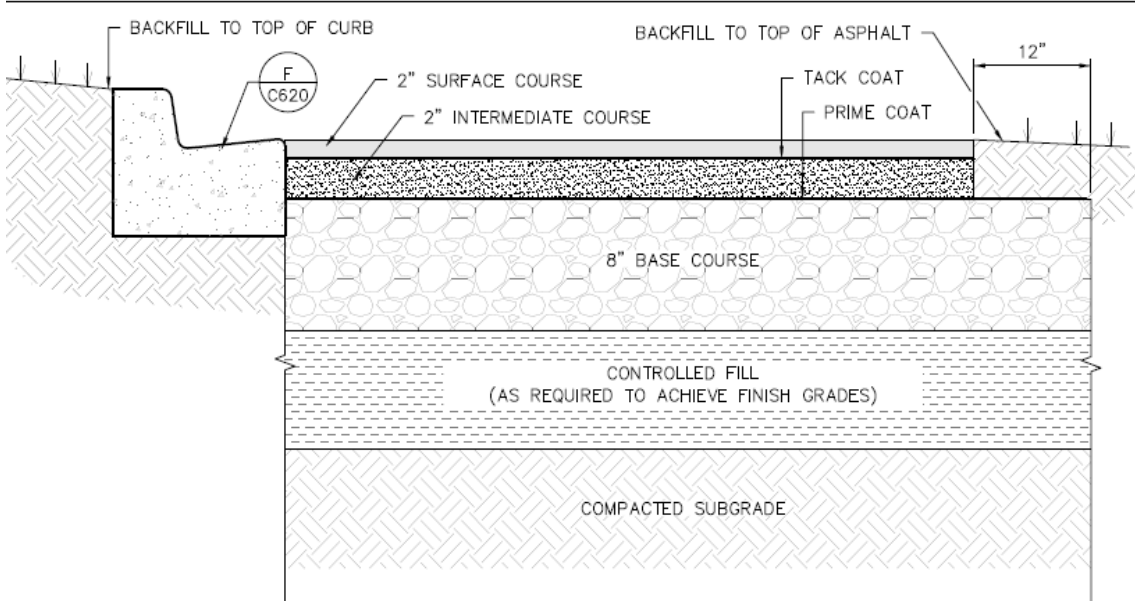

B HEAVY DUTY ASPHALTIC CONCRETE PAVEMENT SECTION

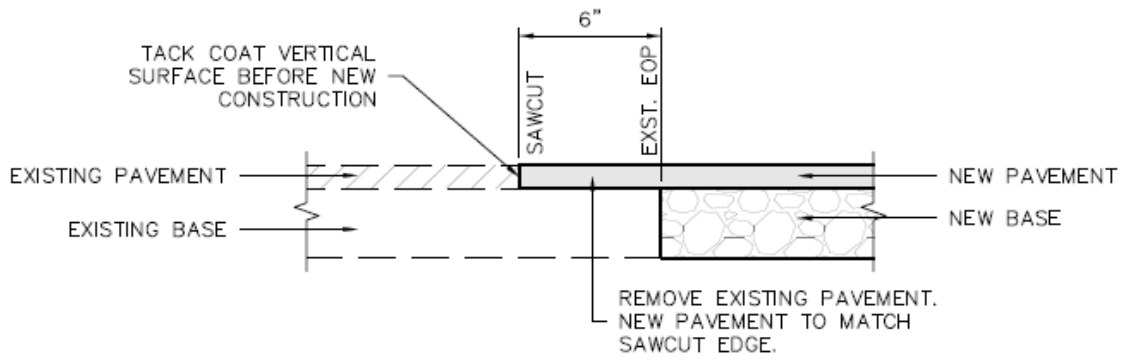

D PAVEMENT TIE-IN TO EXISTING PAVEMENT

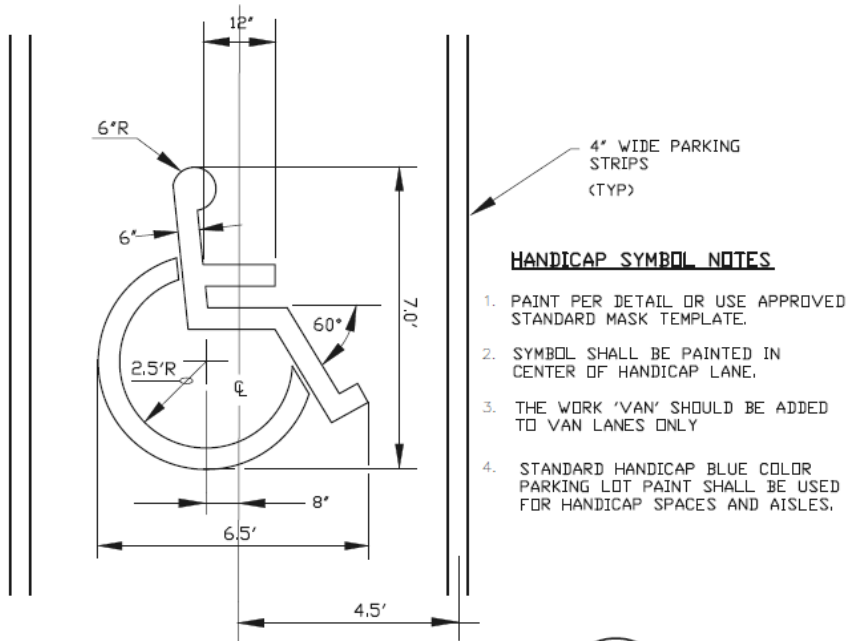

HANDICAP SYMBOL NOTES

1. PAINT PER DETAIL OR USE APPROVED STANDARD MASK TEMPLATE.
2. SYMBOL SHALL BE PAINTED IN CENTER OF HANDICAP LANE.
3. THE WORK 'VAN' SHOULD BE ADDED TO VAN LANES ONLY
4. STANDARD HANDICAP BLUE COLOR PARKING LOT PAINT SHALL BE USED FOR HANDICAP SPACES AND AISLES.

HANDICAP PARKING SYMBOL



NOT TO SCALE

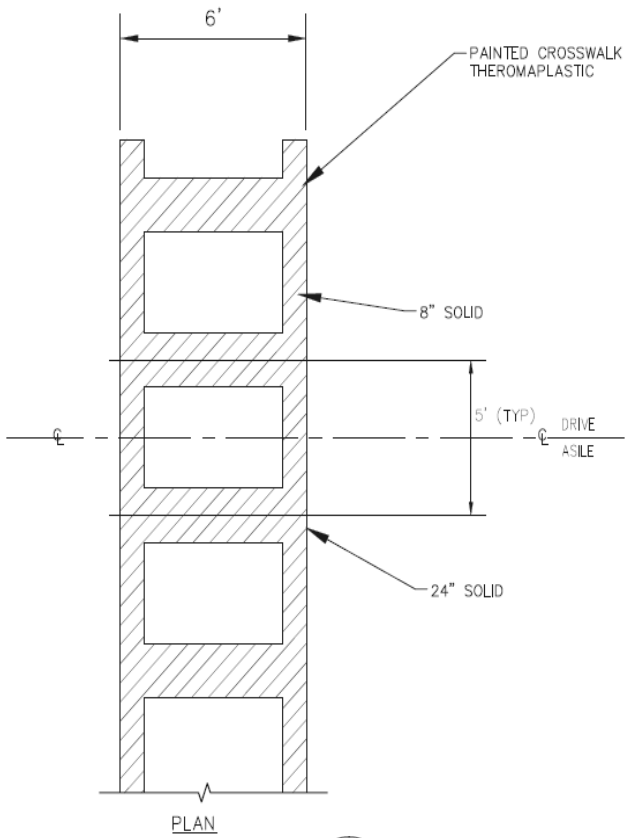

STRIPED WALKWAY (SW)
NTS





20"

ASPHALT SEAL COAT

85.8" EGT

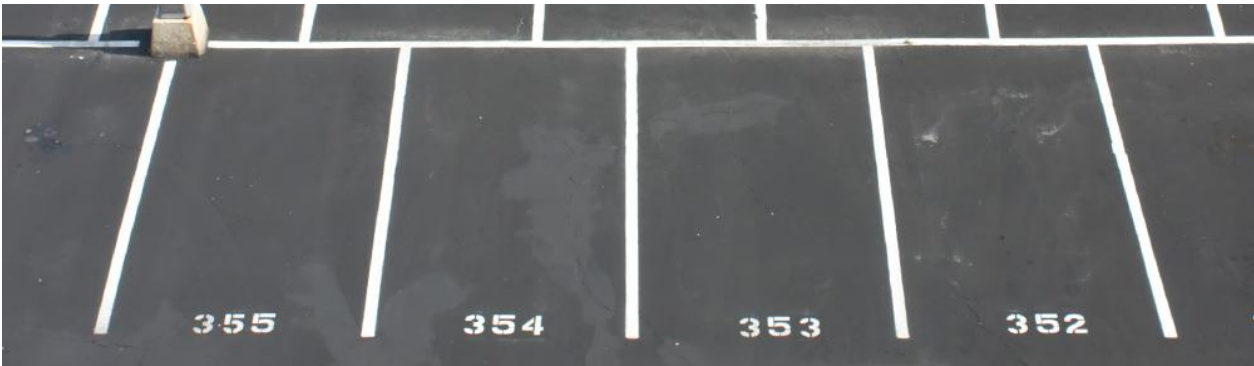

23.11.503.3 International Fire Code Section 503.3 amended – Markings.

Section 503.3 of the International Fire Code is hereby amended to read as follows:

503.3 Marking. Where required by the fire code official fire apparatus access roads shall be marked as follows:

1. FIRE LANE – NO PARKING Signs shall be mounted a minimum of 7' from bottom of the sign to the street or sidewalk. Signs must be a type "R8-31" or equivalent reflective sign no less than 12" x 18" in size, with a white background and the wording "No Parking Fire Lane" in red letters. When in a straight line of sight, these signs shall be no further than one hundred fifty feet (150') apart. This distance may be reduced when curves, corners, or other adverse sighting conditions restrict the line of sight.

2. Designated Fire Department Access Roads (Fire Lanes) shall also be painted red. This shall include both the vertical and horizontal portions of the curb. Minimum three-inch (3") white lettering which shall read: NO PARKING – FIRE LANE, shall be placed every fifty feet (50') or portion thereof on the vertical portion of the curb. The entire curb length shall be painted. If there are rolled curbs or no curbs, stenciling shall be placed on pavement.

Exception: Variations to Fire Lanes markings may be approved when in the opinion of the Fire Code Official the proposed signage and markings achieve the same outcome. The Fire Chief retains the right to revoke the variations for cause.



ALTERNATIVE MARKING METHOD PROPOSED FOR ALL GREENVILLE COUNTY SCHOOLS:

- > ALL CURBS AT POINTS OF ACCESS TO THE BUILDING SHALL BE MARKED.
- > 8" WIDE CONTINUOUS RED BAND MARKED ON PAVEMENT, ADJACENT TO CURBS / WALKS.
- > 3" LETTERING STENCILED AT 50' INTERVALS AS DEPICTED ABOVE.

The School District of Greenville County (District)
Certification of a Drug-Free Workplace
IFB # 523-22-4-28

This certification is required by the Drug-free Workplace Act, Section 44-107-10 *et seq* South Carolina Code of Laws (1976, as amended). The regulation requires signed Certification by Proposers/Contractors/Vendors prior to an award, that the entity shall maintain a drug-free workplace as required below and in accordance with South Carolina law. The signed Certification is a material and binding representation of fact upon which reliance shall be placed when determining the award of a contract. False representation or violation of the Certification requirements shall be grounds for suspension of payments, suspension and/or termination of any contract, or suspension and/or debarment regarding the right to submit bids or proposals to The School District of Greenville County.

For purposes of this Certification, "Drug-free Workplace" is defined as set forth in Section 44-107-20(1), South Carolina Code of Laws (1976, as amended). The aforesaid Section defines a workplace to include any District site where work is performed to carry out the Contractor's/ Vendor's duties under an award/contract. The Contractor's/Vendor's employees shall be prohibited from engaging in the unlawful manufacture, distribution, dispensation, possession, or use of a controlled substance in accordance with the requirements of the Drug-free Workplace Act.

By signing this document, the Contractor/Vendor hereby certifies that it shall provide and maintain a drug-free workplace by:

- (1) Publishing a statement notifying employees that the unlawful manufacture, distribution, dispensing, possession or use of a controlled substance is prohibited on a District site or in the Contractor's/Vendor's workplace and specifying the actions that will be taken against employees for violation of the prohibition;
- (2) Establishing a drug-free awareness program to inform employees about:
 - (a) The dangers of drug abuse in the workplace;
 - (b) The Contractor's/Vendor's policy of maintaining a drug-free workplace;
 - (c) Any available drug counseling, rehabilitation, and employee assistance programs; and
 - (d) The penalties that may be imposed upon employees for drug violations;
- (3) Making it a requirement that each employee to be engaged in the performance of the contract be given a copy of the statement required by paragraph (1) above
- (4) Notifying the employee in the statement required by paragraph (1) that, as a condition of employment under the contract, the employee will:
 - (a) Abide by the terms of the statement; and
 - (b) Notify the employer of any criminal drug statue conviction for a violation occurring in the workplace no later than Five (5) calendar days after the conviction;
- (5) Notifying the District within Ten (10) calendar days after receiving notice under subparagraph (4) (b) from an employee or otherwise receiving actual notice of the conviction;

The School District of Greenville County (District)

Certification of a Drug-Free Workplace

IFB # 523-22-4-28

- (6) The Contractor/Vendor shall take one of the following actions, within Thirty (30) calendar days of receiving notice under subparagraph (4) (b) with respect to any employee who is convicted:
 - (a) Taking appropriate personnel action against the employee, up to and including termination; and
 - (b) Requiring the employee to participate satisfactorily in a drug abuse assistance or rehabilitation program approved for such purposes by a federal, state or local health facility/service, law enforcement agency or other appropriate agency;

- (7) Making a good faith effort to continue to maintain a drug-free workplace through implementation of Paragraphs (1), (2), (3), (4), (5), and (6) above.

*** Please return both page of this form. ***

SDGC Solicitation/Contract Number: IFB No. 523-22-4-28

Project Name: Asphalt Reconditioning – Sixteen Sites

Contractor/Vendor Name:

Address:

Authorized Representative Name/Title:

Signature: _____ **Date:** _____

Witness:

Note: Prior to an award, this Certification Form is required to be submitted for all contracts for a stated or estimated value of \$ 10,000 or more.

BID RESPONSE CERTIFICATION
Invitation for Bid (IFB) No. 523-22-4-28

As an authorized representative of the Bidder, I hereby certify that the costs and services stated in this bid are accurate and binding for not less than ninety (90) calendar days from the solicitation due date. All costs and charges are accurate and complete as stated in the bid are inclusive of all costs the District is expected to pay. If an award is not made within ninety (90) calendar days, it shall be incumbent upon the Bidder to notify the District, in writing, if it does not want its bid further considered. Failure to notify the District shall mean that the bid remains valid until an award is made or the solicitation is cancelled.

I further certify that the Bidder will deliver the service(s) and/or material(s) as required by the Invitation for Bid. No additional costs or payments to any entity, including the Bidder, shall be requested of the District due to any miscalculation, deficiency or other cause later discovered. The Terms and Conditions of the solicitation are accepted by the undersigned.

I certify that the Bidder has availed itself of every opportunity to understand the Invitation for Bid, the District's Procurement Code and Regulations and other pertinent District policy.

By submission of a bid, I certify that the Bidder has read and understands all of the requirements and conditions of the solicitation and shall be bound by such without exception. Therefore, the undersigned respectfully submits the bid.

Firm Name

Mailing Address (Line 1)

Mailing Address (Line 2)

Email Address

Telephone Number

/ Mobile Telephone Number

Printed Name of Authorized Representative

/ Title of Authorized Representative

Signature of Authorized Representative

Date

STANDARD BID FORM
Asphalt Reconditioning – Sixteen Sites
IFB# 523-22-4-28

Page 1 of 2

BID OF: _____
(Contractor)

Acknowledge all addendum/addenda: Addendum No. _____

Provide pricing below for the entire **Base Bid** Scope of Work required in the Solicitation Documents, i.e. for Asphalt Reconditioning at Sixteen Sites. The District will not honor hidden and/or undisclosed charges. Do not include S.C. Sales tax in Base Bid pricing. **Bidders must respond to all site requirements.**

<u>District Location</u>	<u>Base Bid Pricing</u>
1. Alexander Elementary	\$ _____
2. Armstrong Elementary	\$ _____
3. Berea High	\$ _____
4. Blythe Academy	\$ _____
5. Cherrydale Elementary	\$ _____
6. Greenview Child Development Center	\$ _____
7. Monarch Elementary	\$ _____
8. Monaview Elementary	\$ _____
9. Paris Elementary	\$ _____
10. Paul L. Dunbar Child Development Center	\$ _____
11. Ralph Chandler Middle	\$ _____

(Continued on next page)

Authorized Signature: _____ Date: _____

Firm Name: _____

STANDARD BID FORM
Asphalt Reconditioning – Sixteen Sites
IFB# 523-22-4-28

District Location

Base Bid Pricing

12. Sevier Middle	\$ _____
13. Slater Marietta Elementary	\$ _____
14. Southside High	\$ _____
15. Sterling Middle/ Charles Townes Center	\$ _____
16. Thomas E. Kerns Elementary	\$ _____

Total Extended Base Bid Price: \$ _____

(Total Sum of Base Bid Pricing for District Location Numbers 1-16)

Authorized Signature: _____ Date: _____

Firm Name: _____

GENERAL TERMS AND CONDITIONS

While effort has been made to separate substantive and procedural matters through the division of a solicitation or agreement into various parts, the distinctions between such categories are not always exact. Consequently, offerors are advised that all contents of a solicitation or agreement will constitute the substantive terms and conditions of the relationship, if any occurs, between the offeror and the District in accordance with this document.

DEFINITIONS

The terms, “vendor”, “contractor”, “prime contractor”, “contractor”, “firm”, “offeror”, “proposer”, “responder”, “supplier”, “entity” or “bidder” may be used interchangeably and refers to the entity offering a bid/proposal. These terms are defined as including a legal business association of one (1) or more persons existing at the time of the bid/proposal submission. The terms “solicitation”, “Invitation for Bid”, “Bid”, “Request for Proposal”, “Proposal”, “Quotation”, “Quote” may be used interchangeably and refers to the solicitation. The term "Agreement" means any transaction or contractual arrangement contemplated or created as a result of, arising out of, or relating to the solicitation and subsequent award. The terms, “The School District of Greenville County”, “Greenville County Schools”, “Customer”, “Owner”, “District”, “SDGC”, “GCSD”, “GCS”, “Board of Trustees” and “Board” may be used interchangeably and refers to the entity issuing the solicitation, receiving and reviewing the proposals and issuing an award. The term “Day” or “Days” refers to calendar days, unless noted otherwise.

GOVERNING LAW

The contractor or offeror shall comply with the laws of the State of South Carolina which require that it be authorized and/or licensed to bid and/or conduct business in said State. By signing an Agreement or by offering a bid or proposal or agreement, contractor agrees to subject itself to the jurisdiction and process of the District’s Procurement Code and Regulations, the courts of the State of South Carolina or federal courts as to all matters and disputes arising or may arise under and in regard to the solicitation, Agreement and the performance thereof, including any questions as to the liability for taxes, licenses or fees levied by the State.

The solicitation and/or Agreement and any dispute, claim or controversy relating to the solicitation and/or Agreement shall, in all respects, be interpreted, construed, enforced and governed by and in accordance with the Procurement Code and Regulations of The School District of Greenville County and the laws of the State of South Carolina. All disputes, claims or controversies relating to the Agreement shall be resolved exclusively by the District’s Chief Procurement Officer or Purchasing Agent/Procurement Director in accordance with Article XIV of The School District of Greenville County’s Procurement Code or in the absence of jurisdiction, the Court of Common Pleas for, or a federal court located in, Greenville County, State of South Carolina. Contractor or offeror agrees that any act by the District regarding the solicitation and/or Agreement is not a waiver of either the District’s sovereign immunity or the District’s immunity under the Eleventh Amendment of the United States’ Constitution. As used in this paragraph, the term “Agreement” means any transaction, contract, understanding or agreement arising out of, relating to, or contemplated by the pertinent solicitation and/or agreement between the proposer and the District.

The District shall not accept, enter into or sign any proposed agreement(s), document(s), offer(s), contract(s), leases(s) and/or provision(s) that materially conflicts with the District’s General Terms and Conditions, the requirements of a solicitation or which are determined not to be in the best interest of the District.

The solicitation and the District’s General Terms and Conditions shall govern and take precedence as the contract between the District and the awarded entity. The terms of the agreement between the District and the successful/awarded entity shall comply with the requirements contained in this solicitation and the District’s General Terms and Conditions.

CONTRACTUAL NEGOTIATIONS

Contract negotiations, if applicable, may be started at the District’s discretion, with the apparent successful offeror. If any points/issues exist that cannot be resolved, so that a final contract, to the mutual satisfaction of all parties, can be reached, negotiations may be initiated with the next qualified offeror. All contractual documents submitted will be subject to approval of the District.

CONTRACT DOCUMENTS & ORDER OF PRECEDENCE

- (a) Any contract resulting from this solicitation shall include the following documents: (1) a Record of Negotiations, if any, executed by the vendor and the District, (2) documentation regarding the clarification of an offer, if applicable, (3) the solicitation, as may be amended, (4) modifications, if any, to an offer, if accepted by the District, (5) the vendor's offer, (6) any statement reflecting the District's final acceptance (award), (7) purchase orders, and (8) any related contracts or agreements executed by the District and the proposer. These documents shall be read to be consistent and complimentary. Any document signed or otherwise agreed to by persons other than the Executive Director of Finance or a Procurement Officer shall be void and of no effect.

OFFEROR RESPONSIBILITY

The offeror is the entity that is proposing or offering to perform work or supply service(s) and/or material(s) to the District. Each offeror shall fully acquaint itself with conditions relating to the scope and restrictions attending the performance of obligations under the conditions of this solicitation or agreement. The omission of an offeror to acquaint itself with existing pre-contract conditions or post-contract consequences shall in no way relieve such offeror of any obligation with respect to the proposal or to any contract resulting from a solicitation or agreement. Offerors are notified that failure to inspect, familiarize or otherwise gather information as to the total cost to the District will, in addition to any and all other remedies available, create cost difference liabilities and claims against the ultimately successful contractor. Offerors shall notify the District of all costs reasonably expected.

BID/PROPOSAL/AGREEMENT CONSTITUTES OFFER

By submitting a bid/proposal or agreement, the offeror agrees to be governed by the terms and conditions as set forth in the solicitation document or proposed agreement and the District Procurement Code and Regulations. Any bid or proposal response or proposed agreement containing variations from the terms and conditions set forth herein may, at the sole discretion of the District, render such bid or proposal or agreement non-responsive. Any inconsistencies between the solicitation and any other contractual instrument shall be governed by the terms and conditions of the solicitation or proposed agreement, except where subsequent amendments to any contract resulting from the award are specifically agreed to in writing by the parties in order to supersede any such provisions of the solicitation or other contractual document.

SPECIFICATIONS MANDATORY

The offeror must meet all of the mandatory specifications and requirements set forth in the solicitation or proposed agreement. By incorporating said specifications into the offeror's response, subject to acceptance by the District of any amendments hereto as submitted by the offeror, the offeror is agreeing to comply with said solicitation specifications or agreement. Failure to provide mandatory evidence of capability will result in a low evaluation ranking of the offeror's bid/proposal. Items designated as evaluation factors will be evaluated and rated in accordance with the evaluation criteria, if applicable.

INQUIRIES

Every effort has been made to ensure that all information needed by an offeror is included herein. If an offeror finds that it cannot provide a response without additional information, it may submit written questions to the person designated herein on or before the deadline set forth in the solicitation. Questions shall not be accepted by the District after the specified date. All replies to questions will be in writing and contained within an addendum. When a question received by the District is found to be previously and sufficiently addressed in the solicitation, that question will be returned to the proposer with a reference to the part of the solicitation containing the answer. All questions and written replies will be distributed to all known interested firms and individuals via an addendum and will be regarded as a part and parcel of the solicitation.

AMENDMENTS OR ADDENDA

If it becomes necessary to revise any part of the solicitation or agreement, amendments in the form of an addendum will be provided in writing to all known, interested firms and individuals.

ALL AMENDMENTS TO AND INTERPRETATIONS OF A SOLICITATION SHALL BE IN WRITING. THE DISTRICT SHALL NOT BE LEGALLY BOUND BY ANY AMENDMENT, ADDENDUM, INFORMATION OR INTERPRETATION THAT IS NOT IN WRITING.

COMPANY EXPERIENCE AND REFERENCE ACCOUNTS

If requested, interested firms and individuals must provide reference accounts where the services and/or equipment/material(s) offered were similar to the services and/or equipment/material(s) requested in the solicitation. The intent is to show company experience in receiving contracts for, and delivery of, goods and services similar to those proposed. Information should include the name, address, telephone number, and title of the person to contact

for inquiry as to the proposer's experience and performance. Referenced accounts must not be company owned or an affiliate of the bidder or proposer.

The District reserves the right to consider historic information and facts about the bidder or proposer, whether gained from the submitted response, question and answer conferences, references or any other source, during the evaluation process.

SOLICITATIONS/AGREEMENTS SIGNED

All submittals shall be signed by a representative of the entity authorized to commit to the provisions of the submittal. Unsigned bids/proposals will be rejected unless an authorized representative is present at the bid/proposal opening and provides the needed signature, provided that the discovery is made prior to the recording of the contractor's bid/proposal. Any proposed and agreed upon contract shall be signed by an authorized representative of the offeror.

PUBLIC OPENING

All bids/proposals received in response to a solicitation will be recorded publicly at the time and place specified in the solicitation. The name of each offeror shall be announced, recorded and made available for scheduled public inspection.

POSTING OF AWARD

Solicitation awards shall be posted in the District's Procurement Department located at 2 Space Drive, Taylors, South Carolina. Awards may be viewed during normal business hours. The Procurement Department may be contacted to determine if a particular award has been posted.

RIGHT TO PROTEST

Any prospective bidder, proposer, offeror, contractor, or subcontractor who is aggrieved in connection with the solicitation of a contract shall protest in writing to the Purchasing Agent/Director of Procurement within fifteen (15) calendar days of the date of issuance of the Invitation for Bid/Request for Proposal or other solicitation documents, whichever is applicable, or any amendment thereto, if the amendment is at issue.

Any actual bidder, proposer, offeror, contractor, or subcontractor who is aggrieved in connection with the intended award or award of a contract shall protest in writing to the Purchasing Agent/Director of Procurement within fifteen (15) calendar days of the Posting Date as noted on the award document.

PROTEST RIGHTS -- The provisions of Article XIV Section A of the District Procurement Code shall not apply to contracts which are less than \$ 25,000 in total.

A protest shall be submitted in writing to the Purchasing Agent/Director of Procurement, The School District of Greenville County, 2 Space Drive, Taylors, South Carolina 29687 and shall set forth the grounds of the protest, evidence to support the protest and the relief requested with enough particularity to give notice of the issues to be decided.

It shall be agreed that the District may exercise its right to require a protest bond or irrevocable letter of credit from a protesting party when applicable.

CLARIFICATIONS

The District reserves the right, at any time after opening and prior to award, to request from any apparently responsible bidder or proposer, clarification(s) of the bid/proposal submitted to the District, address questions or to seek or provide other information regarding the offeror's submittal/response. This process may be used for such purposes as providing an opportunity for the offeror to clarify its bid/proposal in order to assure mutual understand

PURCHASE ORDERS

Contractor shall not perform any work prior to the receipt of a Purchase Order from the District. The District shall order any supplies or services to be furnished via a solicitation method by issuing a Purchase Order. Purchase Orders may be used to elect any options available pursuant to a solicitation; e.g., quantity, item, delivery date, payment method, but are subject to all terms and conditions of the solicitation.

PATENT AND COPYRIGHT LIABILITY

If notified promptly in writing by the District of any actions (and all prior claims relating to such action) brought against the District, based on a claim that the District's use of the services or any products offered, including software, infringes a United States patent or copyright, the contractor will defend and indemnify the District in such action at its expense and will pay the costs and damages awarded in such action, provided that the contractor shall have sole control of the defense of any such action and all negotiation for its settlement or compromise. The District shall give the Contractor prompt written notice of such claim and full right and opportunity to conduct the defense thereof, together with full information and reasonable cooperation. No cost or expenses shall be incurred for the account of the contractor without its written consent. If principles of government or public law are involved, the District may participate in the defense of any action. If, in the opinion of the contractor, the products furnished there under are likely to, or do become, the subject of a claim of infringement of a United States patent or copyright, then, without diminishing its obligation to satisfy a final award, the contractor may, at its option and expense, (a) obtain the right for the District to continue to use such goods; or (b) substitute, with prior notice and District approval, for the alleged infringing products other equally suitable products that are satisfactory to the District; or (c) take back, with District approval, such products, provided however, that the contractor will not exercise option (c) until the contractor and the District have evaluated options (a) and (b). In such event, contractor will reimburse the District for the purchase price of any goods removed pursuant to option (c).

TAXES

Prices shall include all applicable taxes unless otherwise noted. The current tax rate in South Carolina is six percent (6%). In the event that the contractor fails to pay or delays in paying to any taxing authorities sums paid by the District to the contractor, the contractor shall be liable to the District for any loss (such as the assessment of additional interest) caused by virtue of this failure or delay.

Price Adjustment (Revised 10/06/2021)

Any request for price increase must be submitted to the user location and the District's Procurement Department by the vendor at least sixty (60) calendar days prior to any proposed contract extension, but not before ninety (90) calendar days to the requested renewal contract term. The price increase will only become effective if agreed to in writing by the District's Procurement Department. The maximum increase shall not exceed three percent (3%) or the adjusted percent change from the previously reported period shown in the U.S. Department of Labor, Bureau of Labor Statistics, Southeast Consumer Price Index for All Urban Consumers (CPI-U), whichever is less at the time of renewal.

TERMINATION BY DISTRICT

Termination for Non-appropriations:

In the event no funds or insufficient funds are appropriated and budgeted in any fiscal year for payments due under this Agreement, or there is no further need for the equipment, material(s), service(s) and program products to satisfy the need for which same were acquired herein, then the District shall promptly notify the contractor of such occurrence, and this Agreement shall create no further obligation of the District as to such current or succeeding fiscal year and shall be null and void, except as to the portions of payments herein agreed upon for funds which shall have been appropriated and budgeted. In such event, this Agreement shall terminate on the last day of the fiscal year for which appropriations were received without penalty or expense to the District of any kind whatsoever.

Subject to the provisions below, any contract resulting from this solicitation, or any portion thereof, may be terminated by the District providing a sixty (60) calendar day advance notice in writing is given to the contractor, unless the District agrees to a different notice period.

SUSPENSION BY DISTRICT

The District reserves the right to suspend Contractor's work, with or without cause, upon three (3) calendar day's written notice. If the suspension was not due to any default by Contractor, the District will reasonably and equitably adjust the amount(s) to be paid to Contractor when work is resumed.

TERMINATION BY CONTRACTOR

Requests for termination of a contract by the contractor must be received in writing by a District Procurement Officer at least sixty (60) calendar days prior to the requested contract termination date.

WAIVERS

No waiver of right, obligation, or default shall be implied, but must be in writing, signed by the party against whom the waiver is sought to be enforced. One or more waivers of any right, obligation, or default shall not be construed as a waiver of any subsequent right, obligation, or default.

APPROVAL OF PUBLICITY RELEASES

The contractor shall not have the right to include the District's name in its published list of customers or use of the District or individual school logo without prior approval of the District. The contractor agrees not to publish or cite in any form any comments or quotes from District staff. Contractor further agrees not to refer to award of this contract in commercial advertising in such a manner as to state or imply that the products or services provided are endorsed or preferred by the District without the written consent of an authorized District official.

AFFIRMATIVE ACTION

The successful bidder shall perform this project in compliance with all Federal and State requirements concerning fair employment of all employees and applicants. Vendors shall promote the employment of the disabled and disadvantaged and shall employ without regard or discrimination due to the reason of ethnic background, age, color, religion, gender, national origin, or physical disability. Vendors should provide information regarding the use of minority subcontractors if applicable or if requested by the District. Assistance to minority and disadvantaged firms and individuals is available in accordance with the District's Minority Business Enterprise Utilization Plan. Vendors should contact the Procurement Department with questions regarding this plan.

BANKRUPTCY

(a) Notice. In the event the contractor enters into proceedings relating to bankruptcy, whether voluntary or involuntary, the contractor agrees to furnish written notification of the bankruptcy to the District. This notification shall be furnished within five (5) calendar days of the initiation of the proceedings relating to the bankruptcy filing. This notification shall include the date on which the bankruptcy petition was filed, the identity of the court in which the bankruptcy petition was filed, and a listing of all District contracts against which final payment has not been made. This obligation remains in effect until final payment under this contract.

(b) Termination. This contract is voidable and subject to immediate termination by the District upon the contractor's insolvency, including the filing of proceedings in bankruptcy.

INDEMNIFICATION

The School District of Greenville County, its officers, agents, and employees shall be held harmless from liability from any claims, damages, and actions of any nature arising from the use of any materials or equipment furnished by the contractor or actions by the contractor, provided that such liability is not attributable to negligence on the part of the District or failure of the District to use the materials in the manner outlined by the contractor.

The District shall not indemnify and/or hold harmless any proposing entity or its representatives as this action is not statutorily allowed by South Carolina law.

CONTRACTOR RESPONSIBILITY

The contractor alone will be held solely responsible to the District for performance of all contractor obligations under any contract resulting from the awarded solicitation.

The contractor warrants that services will be provided in a professional manner. The contractor shall be responsible for the full performance of any subcontractors and/or suppliers and the District shall rely solely upon said contractor for project compliance and proper contractual performance.

CONTRACTOR'S USE OF DISTRICT PROPERTY

Upon termination of the contract for any reason, the District shall have the right to possession of all District properties, including, but not limited to, current copies of all District application programs and necessary documentation, all data, files, intermediate materials and supplies held by the contractor. Contractor shall not use, reproduce, distribute, display, or sell any data, material, or documentation owned exclusively by the District without the District's written consent, except to the extent necessary to carry out the work. All District property and information is to be considered confidential in nature and shall not be disseminated or transferred without the District's written authorization.

IMPORTANT: Student and Staff Safety

The awarded entity shall be required to verify that criminal conviction inquiries/checks and pertinent criminal background inquiries/checks have been conducted on all of its employees and the subcontractors who may interact with staff and/or students during the performance of the solicitation requirements/awarded Scope of Work or who may have a need to enter District property related to the performance of the contract or who may have access to personal student or District personnel information.

Persons who are identified as a Sex Offender or violator as defined by the South Carolina Code of Laws (Ann. 2006), Paragraph 223-3-400 or other statute or any other states' statutes; are prohibited from entering any of The School District of Greenville County schools at any time, including all District grounds and all District facilities. Persons employed by or under the direction of the contractor or any subcontractor who are under investigation or have been charged with crimes against children or crimes of a sexual or violent nature shall not be allowed on District property.

While performing under this solicitation and subsequent award, a firm/individual/supplier who delivers material and/or a service to a District site at the direction of a contractor and/or a subcontractor shall be considered under the supervision of the contractor and/or subcontractor and shall be in compliance with this requirement. Contractor's and subcontractor's employees are not to interact with students at any time. Contractor's and subcontractor's employees are not to be in areas where students are present or may be present without prior authorization from the school's principal or designee.

Failure by the awarded firm, its subcontractors or any representative of the contractor or subcontractor to observe this requirement or any violation of this solicitation's requirements shall result in the immediate termination of any existing contract and no penalty or other costs shall be levied against the District.

NOTE: All personnel entering District property and/or having contact with students or staff on District property shall be subject to a South Carolina State Law Enforcement Division (SLED) background/criminal check/investigation prior to being allowed entry or the performance of any duties. All schools have automated equipment which allows instant verification of an individual's status.

IMMIGRATION REQUIREMENTS

By signing the bid or proposer, the bidder or proposer certifies that it will comply with the applicable requirements of Title 8, Chapter 14 of the *South Carolina Code of Laws* and agree to provide to the District upon request any documentation required to establish either: (a) that Title 8, Chapter 14 is inapplicable to the bidder and/or its subcontractors or sub-subcontractors; or (b) that the bidder and its subcontractors or sub-subcontractors are in compliance with Title 8, Chapter 14. Pursuant to Section 8-14-60, "A person who knowingly makes or files any false, fictitious, or fraudulent document, statement, or report pursuant to this chapter is guilty of a felony and, upon conviction, must be fined within the discretion of the court or imprisoned for not more than five years, or both." The bidder agrees to include in any contracts with its subcontractors, language requiring the subcontractors to (a) comply with the applicable requirements of Title 8, Chapter 14, and (b) to include in the subcontractor's contracts with the sub-subcontractors, language requiring the sub-subcontractors to comply with the applicable requirements of Title 8, Chapter 14. [07-7B097-1]

Permits, Licenses and Taxes

The bidder shall, at its own expense, prior to an award and prior to commencing services/operations on behalf of the District or under contract with the District, shall acquire all necessary permits, licenses and other approvals as required by law to provide the required services and/or actions in conjunction with a contract award with the District. It is recommended that firms contact the following to learn of any pertinent requirements or licenses:

The South Carolina Secretary of State's office (www.scsos.com)
The South Carolina Department of Revenue
The South Carolina Department of Labor, Licensing and Regulation
The City of Greenville, South Carolina

The District shall not interpret the requirements of other public entities on behalf of the proposer.

Firms shall obtain all necessary permits and licenses required by local, state and Federal law prior to any award or agreement and shall remain in compliance with all applicable statutes and pertinent regulations throughout the term

of performance. Should any permits or licenses be revoked or lapse during the period of performance, the undersigned Procurement Officer shall be notified immediately.

The awarded entity shall pay all excise taxes, retail taxes and other fees imposed. The entity assumes full responsibility for payment of all State and Federal taxes for unemployment, pensions or any Social Security legislation for all its employees and will further comply with all requirements that may be specified in regulations hereafter promulgated by the District's administrative officials.

By submitting a bid/proposal the bidder/proposer affirms that it shall possess and maintain all required license(s) prior to award and throughout the period of performance.

INSURANCE

Contractor shall maintain, throughout the performance of its obligations under this Agreement, a policy or policies of Worker's Compensation insurance with such limits as may be required by law, and a policy or policies of general liability insurance insuring against liability for injury to, and death of, persons and damage to, and destruction of, property arising out of or based upon any act or omission of the contractor or any of its subcontractors or their respective officers, directors, employees or agents. Such general liability insurance shall have limits sufficient to cover any loss or potential loss resulting from a solicitation and/or contract.

CONTRACTOR'S LIABILITY INSURANCE

(1) Contractor shall purchase from and maintain in a company or companies lawfully authorized to do business in South Carolina such insurance as will protect the contractor from the types of claims set forth below which may arise out of or result from the contractor's operations under the contract and for which the contractor may be legally liable, whether such operations be by the contractor or by a subcontractor or by anyone directly or indirectly employed by any of them, or by anyone for whose acts any of them may be liable: (a) claims under workers' compensation, disability benefit and other similar employee benefit acts which are applicable to the work to be performed; (b) claims for damages because of bodily injury, occupational sickness or disease, or death of the contractor's employees; (c) claims for damages because of bodily injury, sickness or disease, or death of any person other than the contractor's employees; (d) claims for damages insured by usual personal injury liability coverage; (e) claims for damages, other than to the work itself, because of injury to or destruction of tangible property, including loss of use resulting thereof; (f) claims for damages because of bodily injury, death of a person or property damage arising out of ownership, maintenance or use of a motor vehicle; (g) claims for bodily injury or property damage arising out of completed operations; and (h) claims involving contractual liability insurance applicable to the Contractor's obligations under the provision entitled Indemnification – Third Party Claims.

(2) Coverage shall be written on an occurrence basis and shall be maintained without interruption from date of commencement of the work until date of final payment. Coverage must include the following on a commercial basis: (i) Premises – Operations, (ii) Independent Contractor's Protective, (iii) Products and Completed Operations, (iv) Personal and Advertising Injury, (v) Contractual, including specific provision for contractor's obligations under the provision entitled Indemnification – Third Party Claims, (vi) Broad Form Property Damage including Completed Operations, and (vii) Owned, Non-owned and Hired Motor Vehicles.

(3) The insurance required by this paragraph shall be written for not less than the following limits of liability or as required by law, whichever coverage is greater.

COMMERCIAL GENERAL LIABILITY:

General Aggregate (per project) \$1,000,000

Products/Completed Operations \$1,000,000

Personal and Advertising Injury \$1,000,000

Each Occurrence \$1,000,000

Fire Damage (Any one fire) \$ 50,000

Medical Expense (Any one person) \$ 5,000

BUSINESS AUTO LIABILITY (including All Owned, Non-owned, and Hired Vehicles):

Combined Single Limit \$1,000,000

OR

Bodily Injury & Property Damage (each) \$750,000

WORKER'S COMPENSATION:

State Statutory

Employers Liability \$100,000 Per Acc.

\$500,000 Disease, Policy Limit; \$100,000 Disease, Each Employee

(4) Required Documentation. (a) Prior to commencement of the work, contractor shall provide to the District a signed, original certificate of liability insurance (ACORD 25). The certificate shall identify the types of insurance,

state the limits of liability for each type of coverage, include a provision for 30 days notice prior to cancellation, name every applicable using governmental unit (as identified on the cover page) as a Certificate Holder, provide that the general aggregate limit applies per project, and provide that coverage is written on an occurrence basis. (b) Prior to commencement of the work, contractor shall provide to the District a written endorsement to the contractor's general liability insurance policy that (i) names the District as an additional insured, (ii) provides that no material alteration, cancellation, non-renewal, or expiration of the coverage contained in such policy shall have effect unless the named governmental unit(s) has been given at least thirty (30) days prior written notice, and (iii) provides that the Contractor's liability insurance policy shall be primary, with any liability insurance of the District as secondary and noncontributory. (c) Both the certificate and the endorsement must be received directly from either the contractor's insurance agent or the insurance company.

(5) Contractor shall provide a minimum of thirty (30) days written notice to the District of any proposed reduction of coverage limits (on account of revised limits or claims paid under the General Aggregate) or any substitution of insurance carriers.

(6) The District's failure to demand either a certificate of insurance or written endorsement required by this paragraph is not a waiver of contractor's obligations to obtain the required insurance.

INDEMNIFICATION - THIRD PARTY CLAIMS

Notwithstanding any limitation in this agreement, Contractor shall defend and indemnify the District, its instrumentalities, agencies, departments, boards, and all their respective officers, agents and employees against all suits or claims of any nature (and all damages, settlement payments, attorneys' fees, costs, expenses, losses or liabilities attributable thereto) by any third party which arise out of, or result in any way from, any defect in the goods or services acquired hereunder or from any act or omission of Contractor, its subcontractors, their employees, workmen, servants or agents. Contractor shall be given written notice of any suit or claim. The District shall allow the Contractor to defend such claim so long as such defense is diligently and capably prosecuted through legal counsel. The District shall allow the Contractor to settle such suit or claim so long as (i) all settlement payments are made by (and any deferred settlement payments are the sole liability of) Contractor, and (ii) the settlement imposes no non-monetary obligation upon the District. The District shall not admit liability or agree to a settlement or other disposition of the suit or claim, in whole or in part, without the prior written consent of Contractor. The District shall reasonably cooperate with the Contractor's defense of such suit or claim. The obligations of this paragraph shall survive termination of the parties' agreement.

ASSIGNMENT

No solicitation response, contract or any of its provisions may be assigned, sublet, or transferred without the prior written consent of the District.

PAYMENT

The District shall pay the Contractor, after the submission of proper invoices or vouchers, the prices stipulated in this contract for supplies delivered and accepted or services rendered and accepted, less any deductions provided in this contract. Unless otherwise specified in this contract, including the purchase order, payment shall not be made on partial deliveries accepted by the District.

INTELLECTUAL PROPERTY INFRINGEMENT

(a) Without limitation and notwithstanding any provision in this agreement, Contractor shall, upon receipt of notification, defend and indemnify the District, its instrumentalities, agencies, departments, boards, and all their respective officers, agents and employees against all actions, proceedings or claims of any nature (and all damages, settlement payments, attorneys' fees (including inside counsel), costs, expenses, losses or liabilities attributable thereto) by any third party asserting or involving an IP right related to an acquired item. The District shall allow the Contractor to defend such claim so long as the defense is diligently and capably prosecuted. The District shall allow the Contractor to settle such claim so long as (i) all settlement payments are made by Contractor, and (ii) the settlement imposes no non-monetary obligation upon the District. The District shall reasonably cooperate with Contractor's defense of such claim. (b) In the event an injunction or order shall be obtained against the District's use of any acquired item, or if in the Contractor's opinion, the acquired item is likely to become the subject of a claim of infringement or violation of an IP right, the Contractor shall, without in any way limiting the foregoing, and at its expense, either: (1) procure for the District the right to continue to use, or have used, the acquired item, or (2) replace or modify the acquired item so that it becomes non-infringing but only if the modification or replacement does not adversely affect the specifications for the acquired item or its use by the District. If neither (1) nor (2), above, is practical, the District may require that the Contractor remove the acquired item from the District, refund to the District any charge(s) paid by the District, and take all steps necessary to have the District released from any further liability. (c) the Contractor's obligations under this paragraph do not apply to a claim to the extent (i) that the

claim is caused by the Contractor's compliance with specifications furnished by the District unless the Contractor knew or reasonably had prior knowledge or suspected its compliance with the District's specifications would infringe an IP right, or (ii) that the claim is caused by the Contractor's compliance with specifications furnished by the District if the District knowingly relied on a third party's IP right to develop the specifications provided to the Contractor and failed to identify such product to the Contractor. (d) As used in this paragraph, these terms are defined as follows: "IP right(s)" means a patent, copyright, trademark, trade secret, or any other proprietary right. "Acquired item(s)" means the rights, goods, or services furnished under this agreement. "Specification(s)" means a detailed, exact statement of particulars such as a statement prescribing materials, dimensions, and quality of work. (e) Contractor's obligations under this clause shall survive the termination, cancellation, rejection, or expiration of this Agreement.

OWNERSHIP OF DATA & MATERIALS

All data, information, material and documentation either specially prepared by Contractor for the District or provided by the District pursuant to this solicitation shall belong exclusively to the District.

PRIVACY – WEB SERVICES

The offeror agrees that any information acquired by about individuals or businesses which are available to the offeror as a result of the performance of this solicitation award/contract shall not be retained beyond the end of the term of the contracted project without the express written consent of the District. Such information shall not be sold, traded, or released in any form to another entity, including affiliates, and shall not be used for any purpose other than performing this contract. Upon request, the contractor shall provide written confirmation of compliance with this clause.

PROPRIETARY SOFTWARE (WHEN APPLICABLE)

Definition

Proprietary software is defined as data programs, non-custom written, non-made for hire software supplied by the contractor on a magnetic tape, disk, semiconductor device or other memory device; or system memory including hard wired logic instructions, microcode and documentation used to describe, maintain and use the programs.

License

The District is hereby granted a non-exclusive, fully paid perpetual license to use the contractor's proprietary software associated with the materials and/or hardware acquired, but only in conjunction with the material, equipment and/or service purchased pursuant to this Agreement.

Title

Title to any proprietary software, provided by the contractor to the District will remain with the contractor.

Trade Secrets

The District agrees that proprietary software is a trade secret of the contractor. The District agrees to take reasonable precautions to protect the trade secret nature of the proprietary software and to prevent its disclosure to unauthorized personnel. The license herein granted cannot be transferred, assigned, or made available by the District for use by any other individual, firm, partnership, or legal entity not affiliated, associated, or connected with the District without the prior expressed written consent of the contractor, which consent will not be unreasonably withheld. Such transfer shall also be conditioned upon the execution by the transferee of a written declaration agreeing to be bound by the terms and conditions of confidentiality provided for in this section.

Source Code

In the event the contractor, at any point during the continued installation and operation of the equipment herein acquired, discontinues the conduct of business, or for any reason fails to continue to support the proprietary software; the District will be provided a copy of the source code for said proprietary software, at no expense to the District.

Escrow for Source Code: In the event the contractor at any point during the continued installation and operation of the software herein acquired discontinues the conduct of business or for any other reason fails to continue to support the software, the District shall be provided a copy of the source code for said software within thirty days at no expense to the District.

For the effective term of this contract, contractor will provide, to a mutually agreed upon escrow agent in the United States, the most recent version of the source code on magnetic media. The proprietary source code shall be deposited into the escrow account within fifteen (15) calendar days of the initiation of the contract, or any major update, non-customized enhancement, version or release of said licensed software.

The source code may be accessed only upon the following conditions:

- a. The contractor refuses to provide software maintenance, bug fixes, upgrades, updates and/or enhancement services under the terms set forth in this contract or as generally provided similarly situated customers; or
- b. The contractor ceases to do business or exist as a valid business entity, as evidenced by an adjudication of bankruptcy or other definitive measure of cessation of operations.

With regards to proprietary software, the District may not sell, assign lease, or otherwise provide said source code(s) to any other person, firm or entity, regardless of modification, without the express written consent of the contractor, its successors, and assigns.

CUSTOMIZED SOFTWARE

Definition

Customized software is defined as made-for-hire, custom written and customer specific computer programs developed for the District by the contractor or by employees or agents of the District on magnetic tape, disk, semiconductor device or their memory device or system memory including hard wired logic instructions, microcode; and documentation used to describe, maintain and use the programs and any and all of the foregoing created in conjunction with this contract.

Title

Title to the customized software rests in the District as set forth herein. The contractor shall thereafter have no right, title or interest in any customized software. As herein used, title includes providing to the District all intellectual elements of the customized software including, but not limited to, developmental, work product, notes, object and source codes and any other items or material regardless of form which would aid the District in understanding, using, maintaining, and enhancing the pertinent customized software.

Software Tools

The contractor shall provide to the District, simultaneous with its initial installation and any subsequent enhancements, upgrades, modifications, "patches", fixes, etc., software tools (including, but not limited to compilers, editors, etc.) that the District may require to maintain or to enhance the customized software. The price for said tools and the cost to train District personnel to maintain and/or to enhance the customized software shall be noted separately and included in the contractor's cost bid/proposal submitted to the District in response to the solicitation.

ETHICS ACT

By submitting an offer, the vendor certifies that it is in compliance with South Carolina's Ethics, Government Accountability, and Campaign Reform Act of 1991, as amended. The following statutes require special attention: (a) Offering, giving, soliciting, or receiving anything of value to influence action of a public employee – Section 8-13-790, (b) Recovery of kickbacks – Section 8-13-790, (c) Offering, soliciting, or receiving money for advice or assistance of a public official – Section 8-13-720, (d) Use or disclosure of confidential information – Section 8-13-725, and (e) Persons hired to assist in the preparation of specifications or evaluation of bids/proposals – Section 8-13-1150.

Any questions regarding the aforementioned General Terms and Conditions shall be directed to The School District of Greenville County Procurement Department, 2 Space Drive, Taylors, South Carolina 29687, (864) 355-1279.
Rev. 2 17.